



Sparkl

ALPHA

NEET 2026

(Re-Exam)

Detailed Solutions Booklet

To Explore Our Personalized Course Visit:

sparkl.me/neet

One exam does not define your potential. What you do next does

Didn't get the result you hoped for in NEET?
Your medical dream is still within reach.

Sparkl's **NEET Repeater Program** helps students improve scores through personalized mentoring, targeted practice, and continuous performance tracking—so they can return stronger, smarter, and more confident next year.

Why Repeaters Choose Sparkl



Personalized Learning Journey

Customized study plans tailored to your needs



Expert Faculty & Mentorship

Guidance from experienced NEET educators



Adaptive Learning Technology

Pinpoint weaknesses and improve faster



Tests, Analysis & Feedback

Practice smarter with data-driven insights



Proactive Doubt Support

Get help when you need it



3 D Concept Labs

Teacher-guided visual learning through interactive 3D simulations



Subject-Specific Courses Available

Need help in Physics, Chemistry, or Biology? Individual subject coaching options are also available.



See Your Predicted NEET 2027 Score & AIR Every Step of the Way

Get an estimated NEET 2027 score and AIR from every test attempt.



Flexible Schedules

Monday–Saturday
Between 10 AM – 9 PM



Flexible Learning Formats

Choose the learning style that works best for you:

- 1:1 Personalized Tutoring
- Small Groups (1:4)
- Focused Batches (1:8)

Discover how a personalized strategy can help you achieve your target score.

Book a FREE Demo Session
(Limited slots available for NEET Repeaters.)

Still unsure about taking a drop year?

Talk to a NEET Mentor.

Get a personalized preparation roadmap - FREE.

Call: 8527171054 or



DATE: 21/06/2026

Test Booklet Code

Sparkl
ALPHA

70

Time : 3 hrs. 15 min.

M.M. : 720

Answer & Solution for

NEET (UG)-2026(Re-Examination)

Important Instructions:

1. The Answer Sheet is inside this Test Booklet. When you are directed to open the test Booklet, take out the Answer Sheet and fill in the particulars on ORIGINAL Copy carefully with Blue/Black ball point pen only.
2. The test is of 3 hours 15 minutes duration and the Test Booklet contains 180 multiple-choice questions (four options with a single correct answer) from Physics, Chemistry and Biology. (Botany and Zoology).
3. Wherever the symbols/constants are not mentioned, they are to be considered as per their standard meaning/value.
4. Each Question carries 4 marks, For each correct response, the candidate will get 4 marks. For each incorrect response, one mark will be deducted from total scores. The Maximum marks are 720.
5. Use Blue/Black Ball point Pen only for writing particulars on this page/marking responses on Answer sheet.
6. Rough work is to be done in the space provided for this purpose in the Test Booklet only.
7. On completion of the test, the candidate must hand over the Answer Sheet to the Invigilator before leaving the Room/Hall. The candidates are allowed to take away this Test Booklet with them.
8. The CODE for this Booklet is "70". Make sure to enter this code in the OMR answer sheet.
9. The candidates should ensure that the Answer Sheet is not folded. Do not make any stray marks on the Answer Sheet. Do not write your Roll No. anywhere else except in the specified space in the Test Booklet/Answer Sheet.
10. Use of white fluid for correction is NOT permissible on the Answer Sheet.
11. Each candidate must show on-demand his/her Admit Card to the Invigilator.
12. No candidate, without special permission of the Centre Superintendent or Invigilator, would leave his/her seat.
13. The candidate should not leave the Examination Hall without handing over their Answer Sheet to the Invigilator on duty and sign (with time) the attendance sheet twice. Cases, where a candidate has not signed the attendance sheet second time, will be deemed not to have handed over the Answer Sheet and dealt with as an Unfair means case.
14. Use of Electronic/Manual Calculator is prohibited
15. The candidates are governed by all Rules and Regulations of the examination with regard to their conduct in the Examination Room / Hall. All cases of unfair means will be dealt with as per Rules and Regulations of this examination.
16. No part of the Test Booklet and Answer Sheet shall be detached under any circumstances.
17. The candidates will write the Correct Test Booklet Code as given in the Test Booklet / Answer Sheet in the Attendance Sheet.
18. If a candidate marks more than one answers for a question in the OMR Sheet, it will be treated as incorrect and negative marking will be applicable.

PHYSICS

1. A photon and an electron, each of 20 eV energy, move in free space. The ratio of linear momentum of electron p_e to that of photon p_{ph} , $\frac{p_e}{p_{ph}}$ is:

[Take speed of light = $3 \times 10^8 \text{ ms}^{-1}$, charge of electron = $-1.6 \times 10^{-19} \text{ C}$ and mass of electron = $9 \times 10^{-31} \text{ kg}$]

- (1) 275 (2) $\frac{2}{450}$
 (3) $\frac{1}{250}$ (4) 225

Answer (4)

Sol. $E_e = E_{ph} = 20 \text{ eV}$

$$\Rightarrow P_e = \sqrt{2m_e E_e}, P_{ph} = \frac{E_{ph}}{c}$$

$$\Rightarrow \frac{P_e}{P_{ph}} = \frac{\sqrt{2m_e E_e}}{E_{ph}} c = \sqrt{\frac{2m_e}{E_{ph}}} c$$

$$\begin{aligned} \frac{P_e}{P_{ph}} &= \sqrt{\frac{2 \times 9 \times 10^{-31}}{20 \times 1.6 \times 10^{-19}}} \times 3 \times 10^8 \\ &= \frac{3}{4} \times 10^{-6} \times 3 \times 10^8 = \frac{900}{4} = 225 \end{aligned}$$

2. Water flows in a streamline motion through a horizontal pipe of circular cross-section as shown in the figure. The pressure difference of water between P and Q is 15 Nm^{-2} . The area of cross-section at P and Q are 40 cm^2 and 20 cm^2 , respectively. The rate of flow of water through the pipe, in cm^3s^{-1} , is:

[Take density of water = 1000 kg m^{-3}]

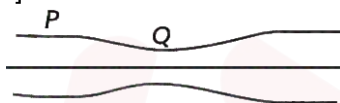

- (1) 400 (2) 100
 (3) 200 (4) 300

Answer (1)

Sol. $A_P V_P = A_Q V_Q$

$$40V_P = 20V_Q, V_Q = 2V_P$$

Using Bernoulli's equation:

$$P_P - P_Q = \frac{1}{2} \rho (V_Q^2 - V_P^2)$$

$$15 = \frac{1}{2} \times 10^3 (4V_P^2 - V_P^2)$$

$$V_P = \sqrt{\frac{15}{1500}} = 0.1 \text{ m/s}$$

$$V_Q = 0.2 \text{ m/s}$$

$$\text{Rate} = A_P V_P = 40 \times 10^{-4} \times 10^{-1} \text{ m}^3/\text{s}$$

$$= 4 \times 10^{-4} \text{ m}^3/\text{s}$$

$$= 4 \times 10^{-4} \times 10^6 \text{ cm}^3/\text{s}$$

$$= 400 \text{ cm}^3/\text{s}$$

3. A thin horizontal disc is rotating about a vertical axis passing through its fixed centre O . Its angular momentum is L_A and L_B computed about points A and B , respectively, with $OB = 2 \times OA$. The value of $\frac{L_A}{L_B}$ is:

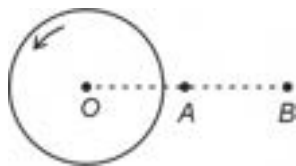

(1) 2

(2) $\frac{1}{4}$

(3) $\frac{1}{2}$

(4) 1

Answer (4)

Sol. $\vec{L} = \vec{r} \times \vec{P} + I_{cm}\vec{\omega}$

$\vec{P} = 0$ for both axis

So $\vec{L}_A = \vec{L}_B = I_{cm}\vec{\omega}$

$\frac{\vec{L}_A}{\vec{L}_B} = 1$

4. Consider a long solenoid of length l and radius r . If n is the number of turns per unit length and μ_0 is the permeability of free space, the inductance of the solenoid is :

(1) $2\mu_0\pi n^2 r^2 l$

(2) $\mu_0\pi n^2 r^2 l$

(3) $\mu_0 n^2 r^2 l$

(4) $(\mu_0/2\pi)n^2 r^2 l$

Answer (2)

Sol. Self-inductance of solenoid

$$L = \frac{N\phi}{i}$$

$$L = \frac{NBA}{i}$$

$$L = \frac{N\mu_0 n i A}{i} \left[n = \frac{N}{l} \right]$$

$$L = N\mu_0 n A$$

$$L = \left(\frac{N}{l} \right) \mu_0 n A l$$

$$L = \mu_0 n^2 A l$$

$$L = \mu_0 n^2 \pi r^2 l \left[\because A = \pi r^2 \right]$$

5. The temperature of a metallic sphere of radius R is increased by a small amount ΔT . If the linear coefficient of thermal expansion of the metal is α , the approximate increase in the volume of the sphere is:

(1) $6\pi R^3 \alpha \Delta T$

(2) $2\pi R^3 \alpha \Delta T$

(3) $3\pi R^3 \alpha \Delta T$

(4) $4\pi R^3 \alpha \Delta T$

Answer (4)

Sol. For the metallic sphere, $\frac{\Delta R}{R} = \alpha \Delta T$

Volume of the sphere, $V = \frac{4}{3}\pi R^3$

$$\therefore \frac{\Delta V}{V} = 3 \frac{\Delta R}{R}$$

$$\text{Increase in volume} = \Delta V = 3 \left(\frac{\Delta R}{R} \right) \left(\frac{4}{3} \pi R^3 \right) = 4\pi R^3 \alpha \Delta T$$

6. Consider two circuits, (A) and (B), each having two resistors. One of them has a positive temperature coefficient of resistance, $+\alpha$, while the other one has a negative temperature of coefficient, $-\alpha$, as shown in the figure. The current through these circuits are denoted by I_A and I_B . At initial temperature, the resistance of the two resistors is R_0 . As the temperature is increased, the correct option that describes the variation of current in these circuits is:

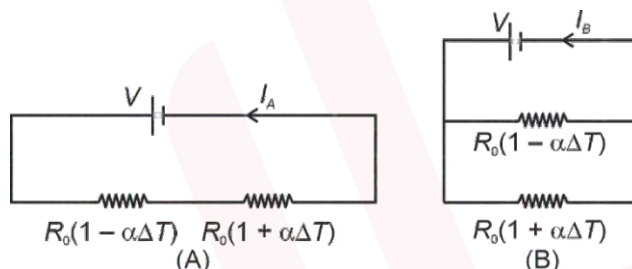

- (1) Both I_A and I_B remain constant
 (2) I_A remains constant while I_B increases
 (3) I_A decreases while I_B increases
 (4) I_A increases while I_B decreases

Answer (2)

Sol. Figure A

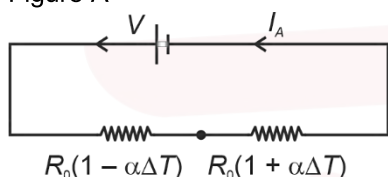

$$R_{eq} = R_0[1 - \alpha \Delta T] + R_0[1 + \alpha \Delta T]$$

$$= 2R_0 = \text{constant}$$

$$\therefore I_A = \frac{V}{2R_0} \rightarrow \text{constant}$$

Figure B

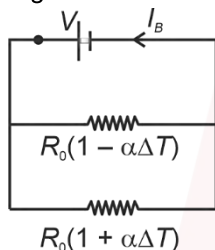

$$R_{eq} = \frac{R_0(1 + \alpha \Delta T) R_0(1 - \alpha \Delta T)}{R_0(1 + \alpha \Delta T) + R_0(1 - \alpha \Delta T)}$$

$$R_{eq} = \frac{R_0(1 - \alpha^2(\Delta T)^2)}{2R_0}$$

R_{eq} will decrease with rise in temperature

$$\therefore I_B = \frac{V_0}{R_{eq}} \text{ increases with rise in temperature}$$

9. In the measurement of viscosity of liquids using terminal velocity experiment, spherical balls of same radius but having different densities are used. The variation of the terminal velocity (v) with the ratio of density of spherical ball (σ) to density of the liquid (ρ), is best represented by:

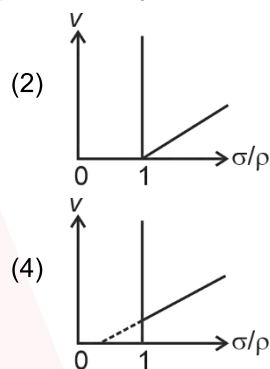
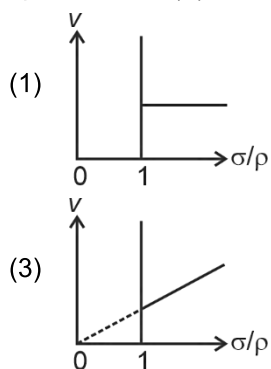

Answer (2)

Sol. Terminal velocity $V_T = \frac{2r^2}{9h}(\sigma - \rho)$

$$V_T = \frac{2r^2}{9h}\rho\left(\frac{\sigma}{\rho} - 1\right) \quad \dots(I)$$

$$y = mx + c \quad \dots(II)$$

Equation number (I) is like equation number which is straight line with negative intercept.

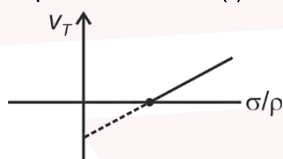

10. Two planets P_1 and P_2 with equal mass have radii R_1 and R_2 , respectively, where $R_2 = \frac{R_1}{2}$. The escape speeds of P_1 and P_2 are v_1 and v_2 , respectively. Then $\frac{v_2}{v_1}$ is:

- (1) 2
(2) $\frac{1}{\sqrt{2}}$
(3) 1
(4) $\sqrt{2}$

Answer (4)

Sol. $V_e = \sqrt{\frac{2GM}{R}}$

$$V_e \propto \frac{1}{\sqrt{R}} \quad [\because M = \text{constant}]$$

$$\frac{V_{e2}}{V_{e1}} = \sqrt{\frac{R_1}{R_2}} = \sqrt{2}$$

11. An ac voltage $V = 220 \sin(2 \times 10^3 t)$ Volt is applied to a series LCR circuit. Then the current amplitude in this circuit is:

(Given : $L = 10 \text{ mH}$, $C = 25 \mu\text{F}$, $R = 100 \Omega$)

- (1) 22.0 A
(2) 2.2 A
(3) 5.5 A
(4) 11.0 A

Answer (2)

Sol. Angular frequency of AC source, $\omega = 2 \times 10^3 \text{ rad/s}$

Inductive reactance, $X_L = \omega L = (2 \times 10^3) \times (10 \times 10^{-3}) = 20 \Omega$

Capacitive reactance, $X_C = \frac{1}{\omega C} = \frac{1}{(2 \times 10^3) \times (25 \times 10^{-6})} = 20 \Omega$

Impedance Z for circuit = R ($\because X_L = X_C$ and circuit is at resonance)

\therefore current amplitude, $i_0 = \frac{V_0}{Z} = \frac{V_0}{R} = \frac{220}{100} = 2.2 \text{ A}$

12. Two identical inductors are connected in two different configurations P and Q , where a time varying current $I(t)$ is flowing, as shown in the figure. The induced emf between points a and b for configuration P is E_P and that for configuration Q is E_Q . The ratio E_P/E_Q is:

[Neglect the effect of mutual inductance.]

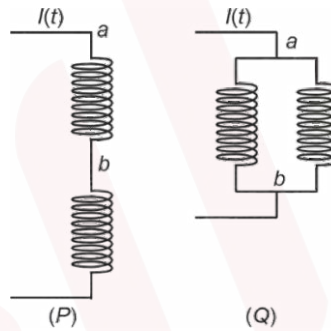

(1) 2

(2) $\frac{1}{4}$

(3) $\frac{1}{2}$

(4) 1

Answer (1)

Sol. In figure (P)

$$E_P = E_{ab} = - \frac{L dI(t)}{dt} \dots(1)$$

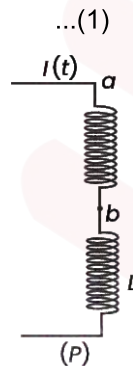

In figure (Q)

$$E_Q = E_{ab} = - \frac{L dI(t)}{2 dt} \dots(2)$$

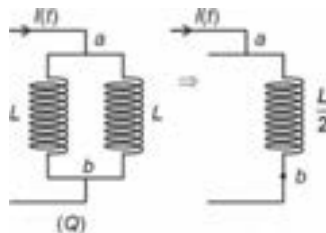

$$\Rightarrow \frac{E_P}{E_Q} = \frac{2}{1}$$

Sol. $A = A_0(1 + \sin t)$

$\phi = BA = BA_0(1 + \sin t)$

$\varepsilon = -\frac{d\phi}{dt} = -BA_0 \cos t$

$I_{\text{induced}} = \frac{\varepsilon_{\text{ind}}}{R} = -\frac{BA_0}{R} \cos t$

Power = $P = I^2 R = \frac{B^2 A_0^2 \cos^2 t}{R}$

$P \propto \cos^2 t$

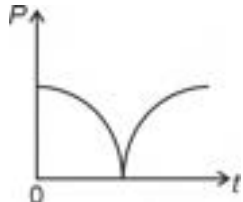

15. In an adiabatic expansion, the temperature of one mole of an ideal monatomic gas ($\gamma = 5/3$) decreases from 60 K to 50 K. The work done by the gas in the process is:

(Take the universal gas constant as $R = 8.3 \text{ J mol}^{-1} \text{ K}^{-1}$)

(1) 166 J

(2) 41.5 J

(3) 83 J

(4) 124.5 J

Answer (4)

Sol. Work done in adiabatic process

$W = \frac{nR\Delta T}{1-\gamma}$

$\Delta T = -10\text{K}$

$W = \frac{1 \times 8.3 \times (-10)}{1 - \frac{5}{3}}$

$W = \frac{83 \times 3}{2}$

$W = 124.5 \text{ J}$

16. Consider a particle moving along a straight line, whose position as a function of time is given by $s(t) = \alpha t^2 - \beta t + \gamma$, where $\alpha = 1 \text{ ms}^{-2}$, $\beta = 6 \text{ ms}^{-1}$ and $\gamma = 5 \text{ m}$. The average speed of the particle, in ms^{-1} from $t = 0$ to $t = 6 \text{ s}$ is:

(1) 0

(2) 12

(3) 6

(4) 3

Answer (4)

Sol. Position (s)

$S = \alpha t^2 - \beta t + \gamma$

$S = t^2 - 6t + 5$

...(i)

Velocity (v)

$v = \frac{ds}{dt} = 2t - 6$

...(ii)

When $v = 0 = 2t - 6$

$t = 3 \text{ s}$

From (ii), graph between (v/t)

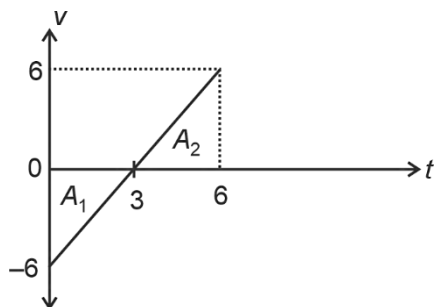

For distance

$$d = (+A_1) + A_2$$

$$d = \frac{1}{2} \times 3 \times 6 + \frac{1}{2} \times 3 \times 6$$

$$d = 3 \times 6 = 18$$

$$\text{Average speed } (v_{\text{avg}}) = \frac{\text{Distance}}{\text{Time}} = \frac{d}{\Delta t} = \frac{18}{6} = 3 \text{ ms}^{-1}$$

17. The following table presents the part of the electromagnetic spectrum and their corresponding major applications.

	Part of the electromagnetic spectrum		Applications
P.	Microwave	I.	For purifying the water
Q.	UV rays	II.	For warming the food
R.	Gamma rays	III.	For AM and FM communication systems
S.	Radio wave	IV.	For treating the Cancer cells

The **correct** option is:

- (1) P-II, Q-IV, R-III, S-I
 (2) P-I, Q-II, R-III, S-IV
 (3) P-I, Q-IV, R-II, S-III
 (4) P-II, Q-I, R-IV, S-III

Answer (4)

Sol.

Part of the electromagnetic spectrum		Applications
Microwave	–	For warming of food
UV rays	–	For purifying the water
Gamma rays	–	For treating the cancer cells
Radio wave	–	For AM and FM communication systems

18. An ideal gas is made of polyatomic molecules. Each of the molecules has three translational, three rotational and f number of vibrational modes. If the ratio of heat capacities C_P/C_V of the gas is $8/7$, then the value of f is:

- (1) 1
 (2) 4
 (3) 3
 (4) 2

Answer (2)

Sol. The total internal energy for one mole of gas, U

$$= \left(\frac{3}{2}k_B T + \frac{3}{2}k_B T + f k_B T \right) N_A$$

$$= (3 + f)k_B T N_A = (3 + f)RT$$

$$\therefore C_V = \frac{dU}{dT} = (3 + f)R$$

$$C_P = C_V + R = (4 + f)R$$

$$\Rightarrow \frac{C_P}{C_V} = \frac{4 + f}{3 + f} = \frac{8}{7} \text{ (given)}$$

$$\Rightarrow f = 4$$

19. A unit positive point charge is taken slowly through an infinitesimally thin tube that is inside a charged dielectric sphere of radius R , having uniform positive charge density ρ , as shown in the figure. The initial and final positions of the charge are marked by A and B at distance $2R$ and $3R$ respectively, from the centre of the sphere. In this process, the magnitude of the total work done on the point charge is $\frac{\rho R^2}{n\epsilon_0}$. The value of n is :

(ϵ_0 is the permittivity of vacuum)

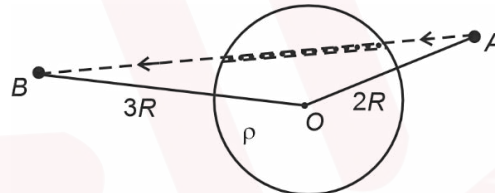

(1) 18

(3) 6

Answer (1)

Sol. Work done $W = q(V_B - V_A)$

$$= q \left[\frac{KQ}{3R} - \frac{KQ}{2R} \right] = \frac{Kq}{R} \left[\frac{-Q}{6} \right]$$

$$|W| = \frac{KqQ}{6R} = \frac{1}{4\pi\epsilon_0} \times \frac{q}{R} \times \frac{1}{6} \times \rho \times \frac{4}{3}\pi R^3$$

$$|W| = \frac{\rho R^2}{18\epsilon_0} \text{ [}\because q = 1\text{]}$$

$$\therefore n = 18$$

(2) 2

(4) 9

20. A current I_0 flows through a metallic circular loop of radius r as shown in the figure. Resistance of the segment ABC is half that of ADC . Magnitude of magnetic field at the centre O of the loop is :

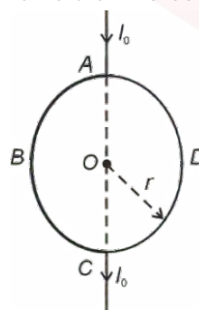

(1) $\frac{\mu_0 I_0}{2\pi r}$

(3) $\frac{\mu_0 I_0}{4r}$

Answer (2)

(2) $\frac{\mu_0 I_0}{12r}$

(4) $\frac{\mu_0 I_0}{2r}$

Sol.

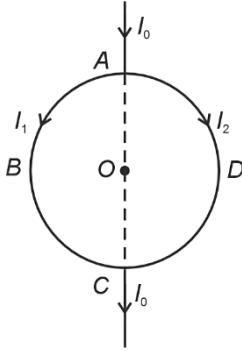

$$I_1 + I_2 = I_0$$

$$2I_2 + I_2 = I_0$$

$$\vec{B}_0 = \vec{B}_1 + \vec{B}_2$$

$$= \frac{\mu_0 I_1 (\bullet)}{4r} + \frac{\mu_0 I_2 (\times)}{4r}$$

$$= \frac{\mu_0 2I_0}{4r \times 3} - \frac{\mu_0 I_0}{4r \times 3} = \frac{\mu_0 I_0}{12r}$$

$$I_1 R_{ABC} = I_2 R_{ADC}$$

$$I_1 + I_2 = I_0$$

$$I_1 \frac{R}{2} = I_2 R$$

$$\frac{I_1}{2} = I_2$$

$$I_2 = \frac{I_0}{3}$$

$$I_1 = \frac{2I_0}{3}$$

21. Bob B of mass m at rest is hanging vertically from the ceiling via a massless string of length 10 m, as shown in the figure. Point mass A of mass m travelling horizontally with speed 10 ms^{-1} hits bob B elastically. The bob B rises h meter after the collision. Taking the acceleration due to gravity $g = 10 \text{ ms}^{-2}$ and neglecting the size of the bob, the value of h is:



(1) 2.5

(3) 7

(2) 8

(4) 5

Answer (4)

- Sol.** • To reach the horizontal position, velocity of bob should be $= 10\sqrt{2} \text{ m/s}$
• Velocity of bob and point mass will be interchanged after elastic collision

By conservation of energy

$$mgh = \frac{1}{2}mv^2$$

$$h = \frac{v^2}{2g}$$

$$h = \frac{(10)^2}{2 \times 10}$$

$$h = 5 \text{ m}$$

22. An electromagnetic wave travelling in a lossless dielectric medium having a dielectric constant, $\epsilon_r = 9$, has the electric field, $E_x = E_0 \sin(kz - 2\pi \times 10^6 t)$ Vm^{-1} where E_0 is the amplitude and k is the wave vector. Among the following options, the **incorrect** choice is
- (1) The direction of propagation of the electromagnetic wave is along +z
 - (2) The speed of the electromagnetic wave inside the medium is 10^8 ms^{-1}
 - (3) The wavelength of the electromagnetic wave inside the medium is 300 m
 - (4) The magnetic field is given by the relation $B_y = \frac{B_0}{v} \sin(kz - 2\pi \times 10^6 t)$ where v is the speed of the electromagnetic wave inside the medium

Answer (3)

Sol.

$$\Rightarrow E_x = E_0 \sin(kz - 2\pi \times 10^6 t) = E_0 \sin(kz - \omega t)$$

\Rightarrow Direction of propagation of wave is along +z axis.

\Rightarrow Speed of wave in medium

$$v_m = \frac{v_0}{\sqrt{\epsilon_r}} = \frac{c}{\sqrt{9}} = \frac{3 \times 10^8}{3}$$

$$v_m = 10^8 \text{ m/s}$$

\Rightarrow Wavelength in medium = λ_m

$$\lambda_m = \frac{v_m}{f_0} = \frac{10^8}{\frac{2\pi \times 10^6}{2\pi}} = 100 \text{ m } [\because f_0 = \text{constant}]$$

\therefore Wavelength of the electromagnetic wave inside the medium is 100 m.

Note: Among the options, in the expression $B_y = \frac{B_0}{v} \sin(kz - 2\pi \times 10^6 t)$, B_0 should be replaced by E_0 .

23. A particle of mass M moves along a horizontal x axis from $x = 0$ to $x = L$. The coefficient of kinetic friction varies as a function of x as $\mu_k(x) = \mu_0 - \alpha x$, where μ_0, α are constants of appropriate dimensions, so that $\mu_k(L) = 0$. The total work done by the frictional force during the motion is $n\mu_0 MgL$, where g is the acceleration due to gravity. The value of n is:

(1) $\frac{1}{2}$

(2) 3

(3) 1

(4) $\frac{1}{3}$

Answer (1)

Sol. Given $\mu_k(x) = \mu_0 - \alpha x$ and $\mu_k(L) = 0 = \mu_0 - \alpha L \Rightarrow \mu_0 = \alpha L$

Magnitude of work done by frictional force, $W_f = \int dW_f$

where $dW_f = f_k dx = \mu_k N dx = \mu_k Mg dx = (\mu_0 - \alpha x) Mg dx$

$$\therefore W_f = \int_0^L \mu_0 Mg dx - \int_0^L \alpha Mg x dx = \mu_0 Mg [x]_0^L - \alpha Mg \left[\frac{x^2}{2} \right]_0^L$$

$$\Rightarrow n\mu_0 MgL = \mu_0 MgL - \left(\frac{\mu_0}{L} \right) Mg \left(\frac{L^2}{2} \right) = \frac{\mu_0 MgL}{2}$$

$$\Rightarrow n = \frac{1}{2}$$

24. Consider three media P , Q and R with refractive indices 1, 1.25, and 1.5 respectively. The medium Q having a thickness of 5 cm is placed between extended media P and R as shown in the figure. An object O is placed at the centre of medium Q . If viewed from medium P near the normal direction, the apparent depth of O is h_1 . For similar observation from medium R , the apparent depth is h_2 . The value of $|h_1 - h_2|$, in cm, is:

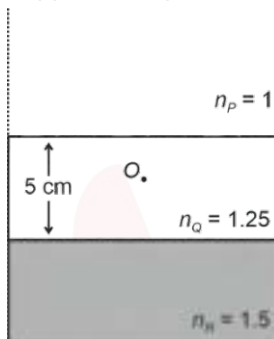

- (1) 3 (2) 0
(3) 1 (4) 2

Answer (3)

Sol. (i) When object O is viewed from medium P ,

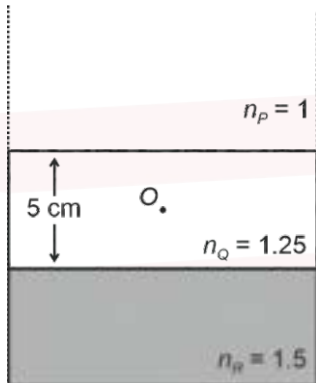

$$\text{Apparent depth } h_1 = \frac{h_{\text{real}}}{\mu} = \frac{2.5}{1.25} = 2 \text{ cm}$$

- (ii) When object O is viewed from medium R ,

$$\text{Apparent depth } h_2 = \mu_{QR} \times 2.5$$

$$= 2.5 \times \frac{1.5}{1.25} = 3 \text{ cm}$$

$$\therefore |h_1 - h_2| = 1 \text{ cm}$$

25. Consider a fixed uniformly charged insulating sphere with radius R and total charge $+Q$. A point charge $-q$ ($q \ll Q$) with mass m is released from rest at a distance of $3R$ from the centre of the charged sphere. When the point charge reaches the surface of the sphere, its speed is:

(ϵ_0 is the permittivity of vacuum, neglect gravitational forces).

(1) $\sqrt{\frac{Qq}{4\pi\epsilon_0 mR}}$

(2) $\sqrt{\frac{3Qq}{4\pi\epsilon_0 mR}}$

(3) $\sqrt{\frac{2Qq}{3\pi\epsilon_0 mR}}$

(4) $\sqrt{\frac{Qq}{3\pi\epsilon_0 mR}}$

Answer (4)

Sol.

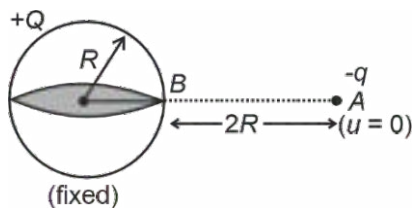

$$\Rightarrow \frac{1}{2}mv^2 = q \left[\frac{KQ}{R} - \frac{KQ}{3R} \right]$$

$$\Rightarrow \frac{1}{2}mv^2 = \frac{kQq}{R} \left[\frac{2}{3} \right]$$

$$\Rightarrow v^2 = \frac{kQq \times 4}{3Rm} = \frac{1 \times Qq \times 4}{4\pi\epsilon_0 \times 3Rm} = \frac{qQ}{3\pi\epsilon_0 Rm}$$

$$v = \sqrt{\frac{Qq}{3\pi\epsilon_0 mR}}$$

26. A car travels on a circular racetrack of radius 50 m, which is banked at an angle θ . If the car travels at a speed 10 ms^{-1} , then the wear and tear on its tyres is minimum. Taking the acceleration due to gravity to be 10 ms^{-2} , the value of θ is:

(1) $\tan^{-1}(2\sqrt{3})$

(2) $\tan^{-1}\left(\frac{1}{5}\right)$

(3) $\tan^{-1}\left(\frac{2}{5}\right)$

(4) $\tan^{-1}(\sqrt{3}/2)$

Answer (2)

Sol. $\tan\theta = \frac{v^2}{rg} = \frac{10 \times 10}{50 \times 10} = \frac{1}{5}$

$$\theta = \tan^{-1}\left(\frac{1}{5}\right)$$

27. A frictionless circular wire of unit radius is fixed on the horizontal plane. Two-point particles of unit mass start moving simultaneously from point $A\left(\theta = \frac{\pi}{2}\right)$ with identical uniform angular speeds in opposite directions, and meet again at point $B\left(\theta = -\frac{\pi}{2}\right)$. During this time, which of the following figures schematically represent the magnitude of the total linear momentum P of the system, as a function of θ ?

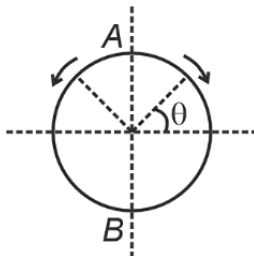

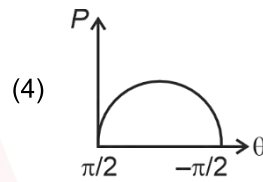
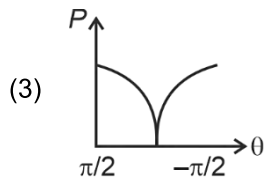
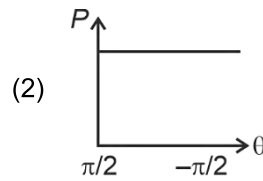
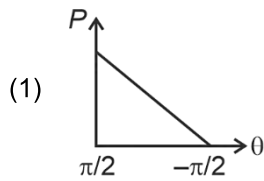

Answer (4)

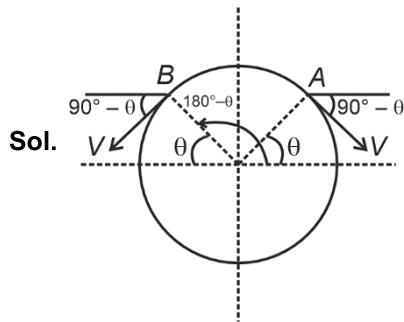

$$\vec{P}_{\text{net}} = -mv \sin \theta \hat{i} - mv \cos \theta \hat{j} + mv \sin \theta \hat{i} - mv \cos \theta \hat{j}$$

$$\vec{P}_{\text{net}} = -2mv \cos \theta \hat{j}$$

at $\theta = \frac{\pi}{2}$, $\vec{P}_{\text{net}} = 0$, at $\theta = -\frac{\pi}{2}$, $\vec{P}_{\text{net}} = 0$

So most appropriate graph is

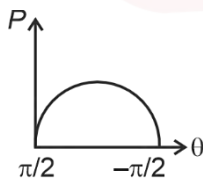

28. Three identical p-n junction diodes D_1 , D_2 , and D_3 are connected across a battery as shown in the figure. If the width of the depletion regions of D_1 , D_2 and D_3 are W_1 , W_2 and W_3 , respectively, then the correct option is:

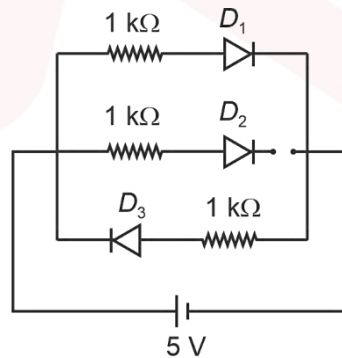

(1) $W_2 > W_1 = W_3$

(2) $W_1 > W_2 > W_3$

(3) $W_3 = W_1 > W_2$

(4) $W_3 > W_2 > W_1$

Answer (4)

Sol. D_1 is forward biased

Depletion region of forward bias (W_1) will be minimum

D_3 is reverse biased

Depletion region of reverse bias (W_3) will be maximum

D_2 is unbiased

Depletion region (W_2) will be between (W_1) and (W_3)

Correct relation will be given as

$$W_3 > W_2 > W_1$$

29. The lens combination as shown in the figure, consists of two lenses, L_1 and L_2 , of the focal lengths +10 cm and -10 cm, respectively. The position of the image formed is:

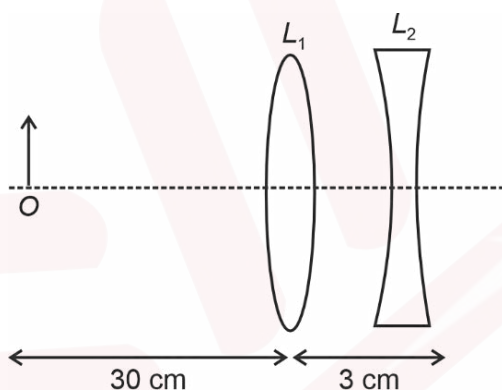

- (1) 60 cm to the right of the concave lens
- (2) 20 cm to the left of the concave lens
- (3) 60 cm to the left of the concave lens
- (4) 30 cm to the right of the concave lens

Answer (3)

Sol. For convex lens L_1 : $u = -30$ cm and $f = +10$ cm

$$\text{Using } \frac{1}{v} - \frac{1}{u} = \frac{1}{f} \Rightarrow \frac{1}{v} + \frac{1}{30} = \frac{1}{10} \Rightarrow \frac{1}{v} = \frac{1}{10} - \frac{1}{30} = \frac{2}{30}$$

$$\therefore v = +\frac{30}{2} = +15 \text{ cm}$$

For concave lens L_2 : $u' = +12$ cm and $f' = -10$ cm

$$\text{Using } \frac{1}{v'} - \frac{1}{u'} = \frac{1}{f'} \Rightarrow \frac{1}{v'} - \frac{1}{12} = \frac{-1}{10} \Rightarrow \frac{1}{v'} = \frac{1}{12} - \frac{1}{10} = \frac{-1}{60}$$

$$\therefore v' = -60 \text{ cm}$$

\Rightarrow Final image formed at 60 cm to the left of concave lens.

30. A solid sphere A of radius R and mass M is attached at a point to a smaller solid sphere B of radius $r < R$ and mass $m < M$. Assume that the line joining their centres lies along the horizontal. The moment of inertia of the system calculated about a vertical axis passing through the centre of A is I_A and that calculated about a vertical axis passing through the centre of B is I_B . The difference $I_A - I_B$ is:

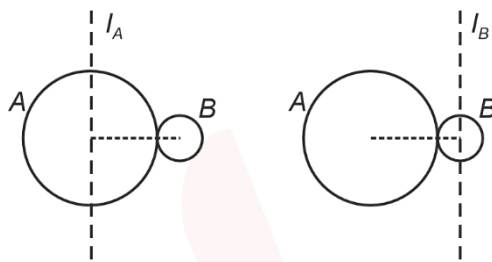

- (1) 0
 (2) $(M - m)(R + r)^2$
 (3) $(m - M)(R + r)^2$
 (4) $(m - M)(R - r)^2$

Answer (3)

Sol. Using $I_C = \frac{2}{5}mR^2$ and Parallel axis theorem, moment of inertia of system

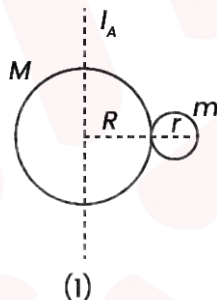

$$I_A = \frac{2}{5}MR^2 + \frac{2}{5}mr^2 + m(R + r)^2 \quad \dots(1)$$

Similarly,

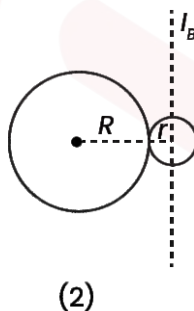

$$I_B = \frac{2}{5}MR^2 + M(R + r)^2 + \frac{2}{5}mr^2 \quad \dots(2)$$

Now, subtracting (1) and (2)

$$I_A - I_B = (m - M)(R + r)^2$$

31. Consider that an electron is revolving in an excited state of Hydrogen atom with velocity $\sqrt{25.6} \times 10^5 \text{ ms}^{-1}$. The radius of the orbit is $x \times 10^{-9} \text{ m}$. The value of x is:

[Take the mass of electron to be $9 \times 10^{-31} \text{ kg}$, charge of electron = $-1.6 \times 10^{-19} \text{ C}$ and $\frac{1}{4\pi\epsilon_0} = 9 \times 10^9 \text{ Nm}^2\text{C}^{-2}$]

- (1) 1 (2) 4
(3) 3 (4) 2

Answer (1)

Sol. $F_c = \frac{mv^2}{r}$

$$\Rightarrow \frac{kq_1q_2}{r^2} = \frac{mv^2}{r}$$

$$\Rightarrow \frac{ke^2}{r} = mv^2 \Rightarrow r = \frac{ke^2}{mv^2} = \frac{9 \times 10^9 \times (1.6 \times 10^{-19})^2}{9 \times 10^{-31} \times 25.6 \times 10^{10}}$$

$$\Rightarrow r = \frac{2.56 \times 10^9 \times 10^{-38}}{25.6 \times 10^{-21}}$$

$$r = 1 \times 10^{-9} \text{ m}$$

$$\therefore x = 1$$

32. The mean free path of molecules in an ideal gas A is half that of another ideal gas B . The diameter of the spherical molecules of gas A is twice the diameter of the molecules of B . If number densities of the gases A and B are n_A and n_B , respectively, the correct option is:

- (1) $n_A = \frac{1}{2}n_B$ (2) $n_A = n_B$
(3) $n_A = 2n_B$ (4) $n_A = \frac{1}{4}n_B$

Answer (1)

Sol. $\lambda_A = \frac{1}{2}\lambda_B$

$$\lambda = \frac{1}{\sqrt{2}\pi d^2 n}$$

$$d_A = 2d_B$$

$$\lambda_A = \frac{1}{\sqrt{2}\pi d_A^2 n_A}$$

$$\lambda_B = \frac{1}{\sqrt{2}\pi d_B^2 n_B}$$

$$\frac{\lambda_A}{\lambda_B} = \frac{1}{2} = \frac{d_B^2 n_B}{d_A^2 n_A}$$

$$\frac{n_A}{n_B} = \frac{2 \cdot d_B^2}{d_A^2}$$

$$\frac{n_A}{n_B} = \frac{2 \cdot d_B^2}{4d_B^2} = \frac{1}{2}$$

33. A cylindrical cork of uniform density floats in a liquid of density ρ_1 . If the cork is depressed slightly and released, it oscillates harmonically with time period T . If the same cork floats in another liquid of density ρ_2 , then the similar oscillation has time period $2T$. The value of ρ_2 / ρ_1 is:

- (1) $1/4$ (2) 4
(3) 2 (4) $1/2$

Answer (1)

Sol. Time period of a cylinder oscillating inside the liquid

$$T = 2\pi \sqrt{\frac{\rho_s l}{\rho_l g}}$$

$$\frac{T_1}{T_2} = \sqrt{\frac{\rho_2}{\rho_1}} \quad [\because \rho_s \rightarrow \text{constant}]$$

$$\frac{T}{2T} = \sqrt{\frac{\rho_2}{\rho_1}}$$

$$\frac{\rho_2}{\rho_1} = \frac{1}{4}$$

34. For sound waves, if the number of nodes for the 5th harmonic of an open-ended pipe is n and that for the 9th harmonic of the same pipe with one of its ends closed is m , the ratio $\frac{n}{m}$ is

- (1) $\frac{3}{5}$ (2) $\frac{5}{9}$
(3) $\frac{9}{5}$ (4) 1

Answer (4)

Sol. For open organ pipe

→ Number of nodes are same as number of harmonics

$$\therefore n = 5$$

For closed organ pipe

→ There are only odd harmonics

For 1st harmonic → Number of node → 1

For 3rd harmonic → Number of node → 2

For 5th harmonic → Number of node → 3

For 7th harmonic → Number of node → 4

For 9th harmonic → Number of node → 5

$$\therefore m = 5$$

$$\rightarrow \frac{n}{m} = \frac{5}{5} = 1$$

35. Consider the following nuclear reaction

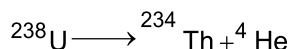

Take masses of ${}^{238}\text{U}$, ${}^{234}\text{Th}$ and ${}^4\text{He}$ as 238.050 u, 234.043 u and 4.003 u, respectively. The Q value for the reaction, in keV, is:

[Given: $1 \text{ u} = 931.5 \text{ MeV c}^{-2}$]

- (1) 3740 (2) 3726
(3) 3730 (4) 3736

Answer (2)

Sol. Q-value for the nuclear reaction is given by, $Q = \Delta mc^2$



$$\Rightarrow \Delta m = 238.050 - (234.043 + 4.003) = 0.004 \text{ u}$$

$$\therefore Q = 0.004 \times 931.5 \text{ MeV} = 3.726 \text{ MeV} = 3726 \text{ keV}$$

36. Which of the following measurements require 'index correction'?

- (1) Measurement of speed of sound using resonance tube
(2) Measurement of resistance of a wire using meter bridge
(3) Measurement of gravitational acceleration using simple pendulum
(4) Measurement of focal length of lenses using optical bench

Answer (4)

Sol. Index correction is an adjustment which need to perform in the experiments related to optical bench while measuring the focal length of lenses using optical bench.

37. In a solar system, the time-period of revolution of a planet tracing a circular orbit of radius R is proportional to:

- (1) R^3 (2) $R^{1/2}$
(3) $R^{3/2}$ (4) R^2

Answer (3)

Sol. In planetary motion

$$T^2 \propto R^3$$

$$T \propto R^{3/2}$$

38. Consider that σ_s , k_B , b represents Stefan-Boltzmann constant, Boltzmann constant and Wien's displacement law constant, respectively. The dimension of $\sigma_s k_B^{-1} b$ is

- (1) $[\text{L}^{-1} \text{T}^{-1} \text{K}^{-4}]$ (2) $[\text{L}^{-1} \text{T}^{-1} \text{K}^{-2}]$
(3) $[\text{L}^{-1} \text{K}^{-2}]$ (4) $[\text{L}^{-1} \text{T}^{-1} \text{K}^{-3}]$

Answer (2)

$$\text{Sol. } \sigma_s = \text{MT}^{-3}\text{K}^{-4}$$

$$k_B = \text{M}^1\text{L}^2 \text{T}^{-2}\text{K}^{-1}$$

$$b = \text{M}^0 \text{LT}^0\text{K}$$

$$\sigma_s k_B^{-1} b = [\text{MT}^{-3}\text{K}^{-4}][\text{M}^{-1}\text{L}^{-2} \text{T}^2\text{K}][\text{M}^0\text{LT}^0\text{K}]$$

$$= \text{T}^{-1}\text{K}^{-2}\text{L}^{-1}$$

$$= \text{L}^{-1} \text{T}^{-1}\text{K}^{-2}$$

44. Two infinitely long parallel conducting wires A and B carry currents I and $2I$, respectively, in the same direction. The wire A has uniform mass per unit length λ and lies on an insulated floor. The wire B is kept fixed at a height h above the floor. The minimum magnitude of h so that the wire A does not rise from the floor is: [g is the acceleration due to gravity and μ_0 is the permeability of free space.]

(1) $\frac{4\mu_0 I^2}{\pi\lambda g}$

(2) $\frac{\mu_0 I^2}{2\pi\lambda g}$

(3) $\frac{\mu_0 I^2}{\pi\lambda g}$

(4) $\frac{2\mu_0 I^2}{\pi\lambda g}$

Answer (3)

Sol.

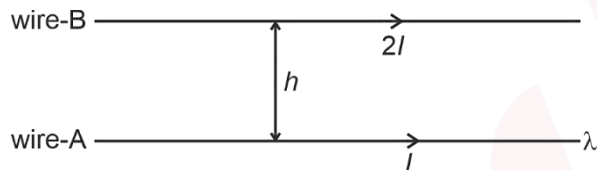

Force per unit length on wire A by wire B

$$F = \frac{\mu_0}{4\pi} \frac{2I \cdot 2I}{h} = \frac{\mu_0}{4\pi} \frac{4I^2}{h}$$

If $F_{net} \leq mg$, weight of wire A , then wire does not rise from the floor.

So, $F \leq mg$,

$$\frac{\mu_0}{4\pi} \frac{4I^2}{h} \leq \lambda g$$

$$\therefore h \geq \frac{\mu_0 I^2}{\pi\lambda g}$$

45. Consider a spring-mass simple harmonic oscillator in one dimension. The mass of the particle is m kg and the spring constant is $k \text{ Nm}^{-1}$. At a given instant, the extension of the spring is x -meter and the speed of the particle is $v \text{ ms}^{-1}$. On the $x - v$ plane, if the graph of v as a function of x is a circle, then the correct option is:

(1) $k = \sqrt{m}$

(2) $k = \frac{1}{m}$

(3) $k = m$

(4) $k = m^2$

Answer (3)

Sol. Velocity v as a function of x is given by

$$v = \omega \sqrt{A^2 - x^2}$$

$$v^2 = \omega^2 (A^2 - x^2)$$

$$\frac{v^2}{\omega^2} + x^2 = A^2$$

Given that above equation is of a circle

Hence, $\omega^2 = 1$

$$\frac{k}{m} = 1$$

$$k = m$$

One exam does not define your potential. What you do next does

Didn't get the result you hoped for in NEET?
Your medical dream is still within reach.

Sparkl's **NEET Repeater Program** helps students improve scores through personalized mentoring, targeted practice, and continuous performance tracking—so they can return stronger, smarter, and more confident next year.

Why Repeaters Choose Sparkl



Personalized Learning Journey

Customized study plans tailored to your needs



Expert Faculty & Mentorship

Guidance from experienced NEET educators



Adaptive Learning Technology

Pinpoint weaknesses and improve faster



Tests, Analysis & Feedback

Practice smarter with data-driven insights



Proactive Doubt Support

Get help when you need it



3 D Concept Labs

Teacher-guided visual learning through interactive 3D simulations



Subject-Specific Courses Available

Need help in Physics, Chemistry, or Biology? Individual subject coaching options are also available.



See Your Predicted NEET 2027 Score & AIR Every Step of the Way

Get an estimated NEET 2027 score and AIR from every test attempt.



Flexible Schedules

Monday–Saturday
Between 10 AM – 9 PM



Flexible Learning Formats

Choose the learning style that works best for you:

- 1:1 Personalized Tutoring
- Small Groups (1:4)
- Focused Batches (1:8)

Discover how a personalized strategy can help you achieve your target score.

Book a FREE Demo Session
(Limited slots available for NEET Repeaters.)

Still unsure about taking a drop year?

Talk to a NEET Mentor.

Get a personalized preparation roadmap - FREE.

Call: 8527171054 or



CHEMISTRY

46. Consider the following reaction, and choose the correct option.

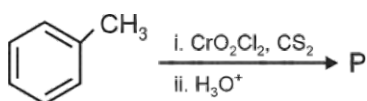

- (1) Compound **P** is obtained by the hydrogenation of benzoyl chloride with Pd on BaSO₄
- (2) On treating compound **P** with saturated NaHCO₃ solution, brisk effervescence is observed
- (3) Compound **P** can be prepared by treating benzene with anhydrous AlCl₃ and CH₃COCl
- (4) On treating with bromine water, compound **P** gives a white precipitate

Answer (1)

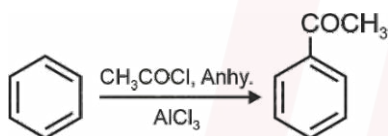
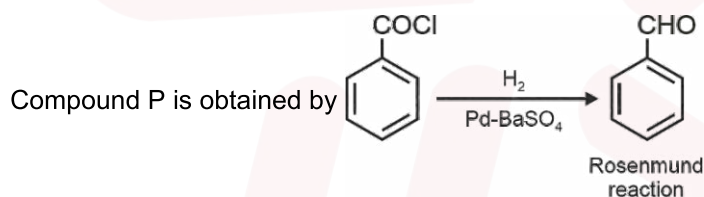
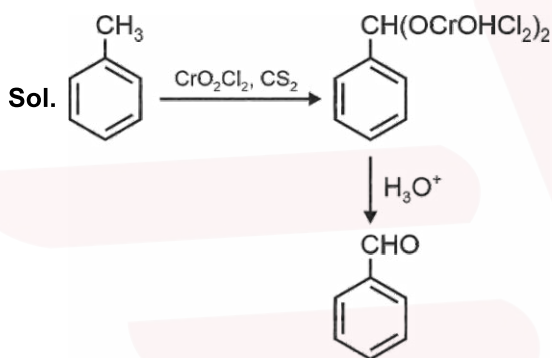

47. The formula of tetraammineaquachloridocobalt(III) chloride is

- (1) [Co(NH₃)₄(H₂O)Cl]Cl₂
- (2) [Co(NH₃)₄Cl₂] × H₂O
- (3) [Co(NH₃)₄]Cl₃ × H₂O
- (4) [Co(NH₃)₄(H₂O)Cl]Cl

Answer (1)

Sol. Tetraammineaquachloridocobalt(III) chloride is [Co(NH₃)₄(H₂O)Cl]Cl₂.

48. The lanthanide ion having four unpaired electrons is
(Given : Atomic numbers of Ce = 58, Nd = 60, Tb = 65 and Ho = 67)

- (1) Ho^{3+}
- (2) Nd^{3+}
- (3) Ce^{3+}
- (4) Tb^{3+}

Answer (1)

Sol. The outermost electronic configuration is

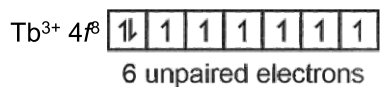

49. For an elementary chemical reaction, the Arrhenius plot is given below.

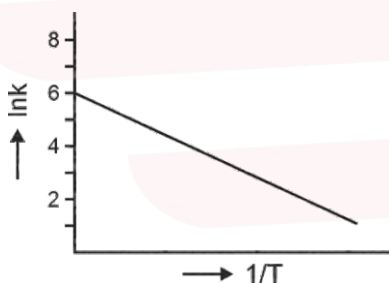

If the energy of activation is 6.64 kJ mol^{-1} and $R = 8.3 \text{ J K}^{-1} \text{ mol}^{-1}$, the temperature at which the rate constant becomes $e^2 \text{ min}^{-1}$, is

- (1) 250 K
- (2) 125 K
- (3) 150 K
- (4) 200 K

Answer (4)

Sol. $\ln k = \ln A - \frac{E_a}{RT}$

$$\ln(e^2) = 6 - \frac{6.64 \times 10^3 \text{ J mol}^{-1}}{8.3 \text{ J K}^{-1} \text{ mol}^{-1} \times T}$$

$$2 = 6 - \frac{6.64 \times 10^3}{8.3 \times T}$$

$$T = \frac{6.64 \times 10^3}{8.3 \times 4} = 200 \text{ K}$$

50. The green paramagnetic species formed by heating KMnO_4 at 513 K is

- (1) KO_2
- (2) K_2MnO_4
- (3) Mn_3O_4
- (4) MnO

Answer (2)



K_2MnO_4 will form on heating KMnO_4 which has green colour.

51. Given below are two statements :

Statement I : *trans*-But-2-ene upon treatment with Br_2 in CCl_4 gives the following product.

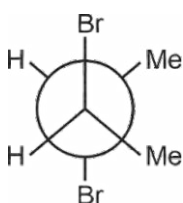

Statement II : *cis*-But-2-ene upon treatment with alkaline KMnO_4 gives the following product.

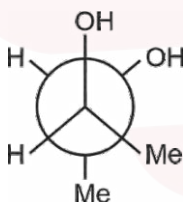

In the light of the above statements, choose the **most appropriate** answer from the options given below.

- (1) **Statement I** is incorrect but **Statement II** is correct
- (2) Both **Statement I** and **Statement II** are correct
- (3) Both **Statement I** and **Statement II** are incorrect
- (4) **Statement I** is correct but **Statement II** is incorrect

Answer (1)

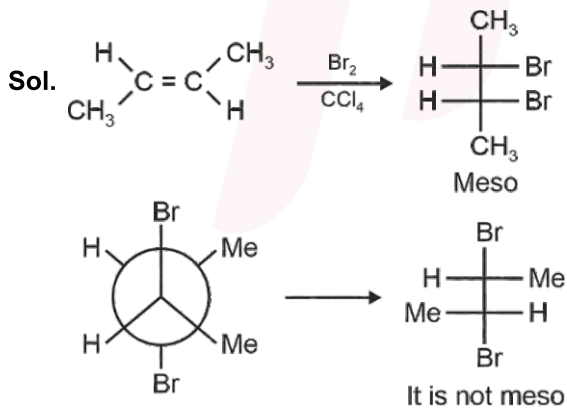

Therefore, statement-I is incorrect.

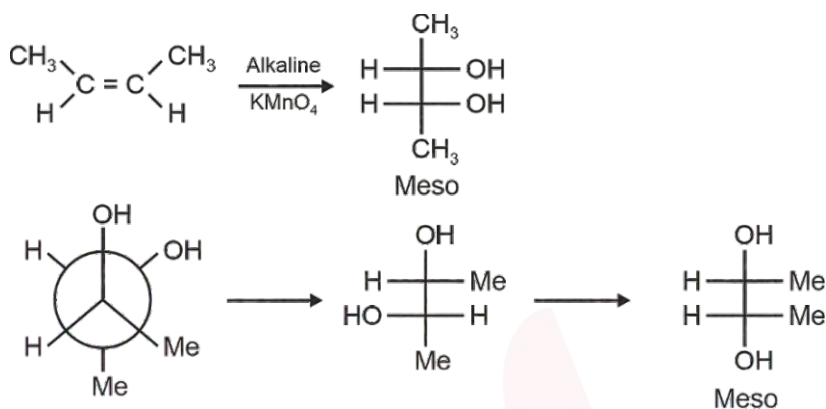

52. One of the products formed in the following reaction is

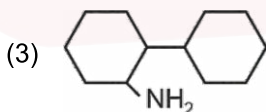
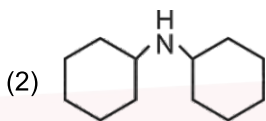
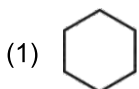
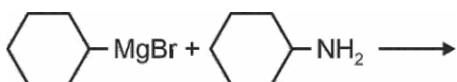

Answer (1)

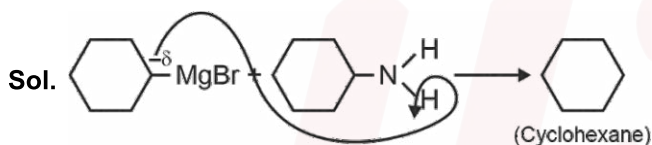

Grignard reagents react with amines to extract proton and convert into corresponding hydrocarbon.

53. Given below are two statements :

Statement-I : Heating NaCl with concentrated H_2SO_4 and MnO_2 results in oxidation of Mn.

Statement-II : Heating NaI with concentrated H_2SO_4 and MnO_2 results in reduction of Mn.

In light of the above statements, choose the **most appropriate** answer from the options given below.

- (1) **Statement-I** is incorrect but **Statement-II** is correct
- (2) Both **Statement-I** and **Statement-II** are correct
- (3) Both **Statement-I** and **Statement-II** are incorrect
- (4) **Statement-I** is correct but **Statement-II** is incorrect

Answer (1)

Sol. Statement-I : (False)

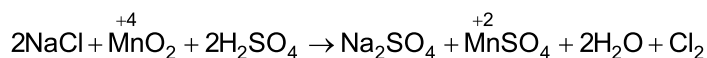

So, reduction of Mn is taking place.

Statement-II : (True)

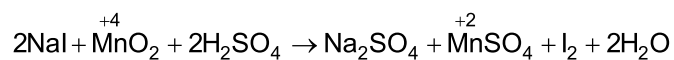

So, Mn has undergone reduction.

54. Among the following options, the correct trend in the electron gain enthalpy is

- (1) I > Br > Cl > F
- (2) F > Cl > Br > I
- (3) Br > Cl > F > I
- (4) Cl > F > Br > I

Answer (4)

Sol.

Group 17 Elements	Electron gain enthalpy (kJ/mol)
F	-328
Cl	-349
Br	-325
I	-295

So, the correct order of electron gain enthalpy is Cl > F > Br > I.

55. Given below are two statements:

Statement-I : $[\text{Fe}(\text{ox})_3]^{3-}$ is chiral.

Statement-II : $\text{trans} - [\text{Cr}(\text{H}_2\text{O})_2(\text{ox})_2]^-$ is chiral.

(Given : $\text{oxH}_2 = \text{HOOC} - \text{COOH}$)

In light of the above statements, choose the **most appropriate** answer from the options given below:

- (1) **Statement-I** is incorrect but **Statement-II** is correct
- (2) Both **Statement-I** and **Statement-II** are correct
- (3) Both **Statement-I** and **Statement-II** are incorrect
- (4) **Statement-I** is correct but **Statement-II** is incorrect

Answer (4)

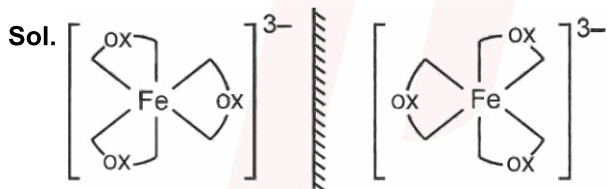

$[\text{Fe}(\text{ox})_3]^{3-}$ is optically active and chiral with two non-superimposable mirror images.

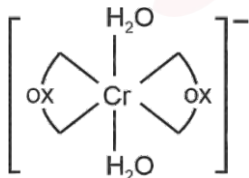

Plane of symmetry (POS) is present in given species.

\therefore It is NOT chiral and optically inactive.

56. The correct statement about peptides and proteins is
- (1) In α -helices, the polypeptide chain is twisted into a left-handed screw (helix) through intramolecular hydrogen bonds
 - (2) Tertiary structure of proteins has two or more polypeptide subunits
 - (3) Only the proteins having a quaternary structure are biologically active
 - (4) In β -pleated sheet structures, peptide chains are held together by intermolecular hydrogen bonds

Answer (4)

Sol. In β -pleated sheet structure, peptide chains are held together by intermolecular hydrogen bonds.

This is only correct statement.

Remaining (1), (2) and (3) are incorrect statements.

57. Given below are two statements:

Statement-I : Oxidation of p-nitrotoluene with acidic KMnO_4 gives an acid that is stronger than benzoic acid.

Statement-II : Reduction of p-nitrotoluene with Sn/HCl followed by neutralization gives an amine that is more basic than aniline.

In light of the above statements, choose the **most appropriate** answer from the options given below.

- (1) **Statement-I** is incorrect but **Statement-II** is correct
- (2) Both **Statement-I** and **Statement-II** are correct
- (3) Both **Statement-I** and **Statement-II** are incorrect
- (4) **Statement-I** is correct but **Statement-II** is incorrect

Answer (2)

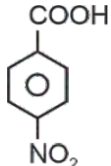
Sol. • Oxidation of p-nitrotoluene with acidic KMnO_4 converts into p-nitrobenzoic acid.  because

of $-I$ effect and $-M$ effect, making p-nitrobenzoic acid as stronger acid than benzoic acid.

- Reduction of p-nitrotoluene with Sn/HCl followed by neutralization reduces the ($-\text{NO}_2$) to an amino group ($-\text{NH}_2$), forming p-toluidine.

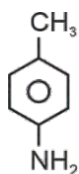

i.e., p-methylaniline is more basic than aniline due to the $+I$ effect and hyperconjugation.

58. Identify the reactions which give aniline as the major product.

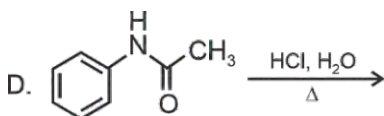
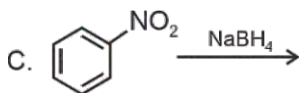
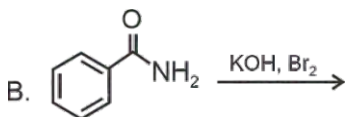
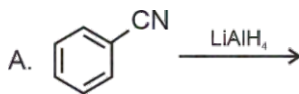

Choose the correct answer from the options given below.

- (1) C and D only
- (2) A and B only
- (3) B and D only
- (4) A and C only

Answer (3)

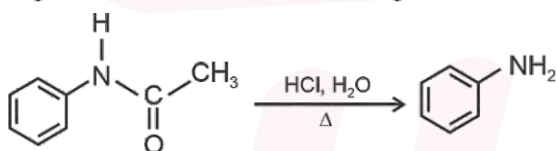
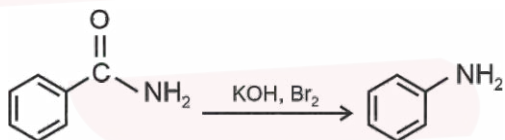
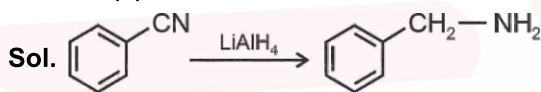

59. Two moles of an ideal gas undergo free expansion from 10 L to 100 L at 300 K. The values of ΔS_{system} and $\Delta S_{\text{surroundings}}$ are

(R is universal gas constant)

- (1) $\Delta S_{\text{system}} = 4.606 R$; $\Delta S_{\text{surroundings}} = 0$
- (2) $\Delta S_{\text{system}} = 0$; $\Delta S_{\text{surroundings}} = 0$
- (3) $\Delta S_{\text{system}} = 4.606 R$; $\Delta S_{\text{surroundings}} = -4.606 R$
- (4) $\Delta S_{\text{system}} = 0$; $\Delta S_{\text{surroundings}} = 4.606 R$

Answer (1)

Sol. During free expansion

$$\begin{aligned} \Delta S_{\text{system}} &= nR \ln \frac{V_2}{V_1} \\ &= 2.303 \times 2 \times R \times \log \frac{100}{10} \\ &= 4.606 R \end{aligned}$$

$$\Delta S_{\text{surroundings}} = 0 \text{ as } q = 0$$

60. The compound that **CANNOT** be obtained from the aldol condensation reaction shown below, is

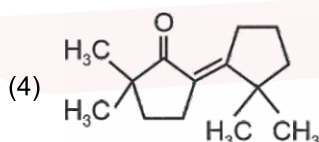
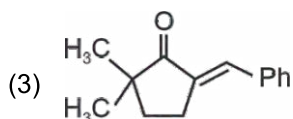
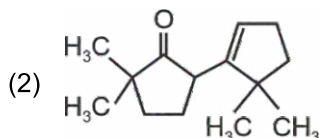
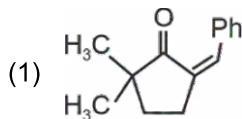
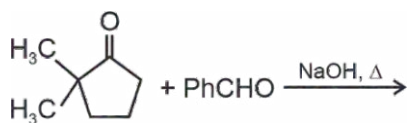

Answer (2)

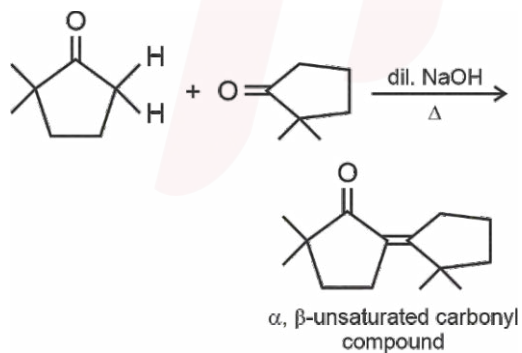
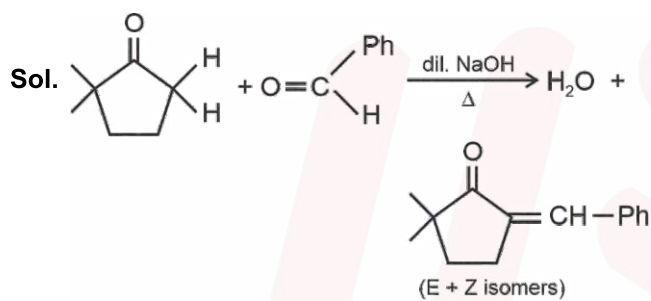

Therefore, compound 2 cannot be obtained by aldol condensation of given compounds.

61. The complex which has facial and meridional isomers is
(Given : py = pyridine and en = H₂N – CH₂ – CH₂ – NH₂)

- (1) [Ni(en)₂(H₂O)₂]²⁺
- (2) [Cr(py)₃(Cl)₃]
- (3) [Cr(H₂O)₆]³⁺
- (4) [Co(NH₃)₄(H₂O)₂]³⁺

Answer (2)

Sol. The complex with type [Ma₃b₃] type of complexes show fac and mer type of isomers.

∴ [Cr(py)₃(Cl)₃] shows fac and mer isomers.

62. The numbers 17.0145 and 21.0235 were rounded to three figures after the decimal point. The resulting numbers, respectively, are

- (1) 17.015 and 21.024
- (2) 17.014 and 21.023
- (3) 17.015 and 21.023
- (4) 17.014 and 21.024

Answer (4)

Sol. If the rightmost digit to be removed is 5, then the preceding number is not changed if it is an even number, but it is increased by one if it is an odd number.

63. The amount of carbon dioxide evolved upon complete combustion of 116 g of n-butane is
(Given: atomic mass in amu H = 1, C = 12 and O = 16)

- (1) 362 g
- (2) 352 g
- (3) 322 g
- (4) 176 g

Answer (2)

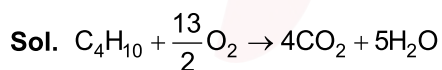

∴ 1 mole C₄H₁₀ produces 4 mole CO₂

∴ 58 g C₄H₁₀ ≡ 4 × 44 g CO₂

∴ 116 g C₄H₁₀ ≡ $\frac{4 \times 44}{58} \times 116 = 352$ g

64. Consider the following schematic plots of orbital wavefunction (ψ_r) against distance (r) from the nucleus.

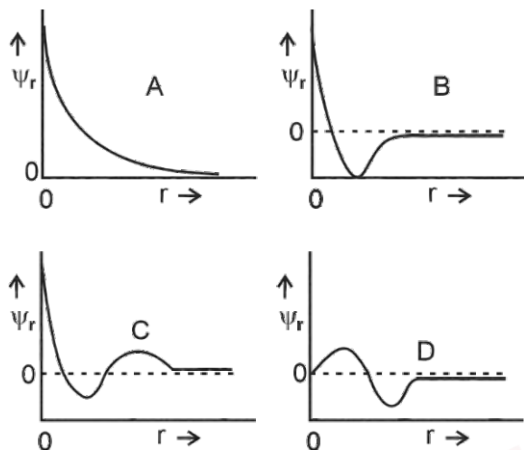

The figure representing two radial nodes in the orbital is

- (1) D
- (2) A
- (3) B
- (4) C

Answer (4)

Sol.

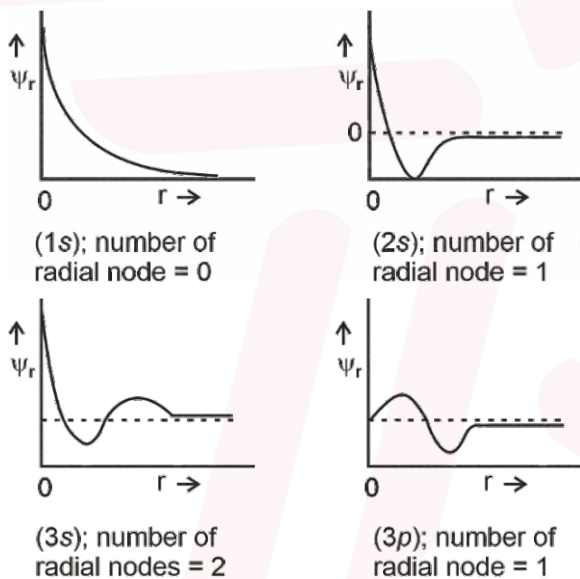

65. The following carbocation is stabilized by the interaction of the empty p orbital with

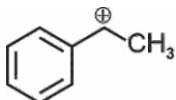

- (1) empty σ^* and empty π^* orbitals
- (2) filled σ and filled π orbitals
- (3) empty σ and empty π^* orbitals
- (4) empty σ^* and filled π orbitals

Answer (2)

Sol.

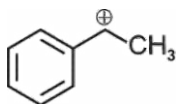

Due to resonance it is stabilised by filled π orbital.

Due to hyperconjugation, it is stabilised by filled σ orbitals.

66. A 1 : 3 electrolyte in an aqueous solution is

- (1) $[\text{Co}(\text{NH}_3)_3(\text{NO}_2)_3]$
- (2) $[\text{CoCl}_2(\text{NH}_3)_4]\text{Cl}$
- (3) $[\text{CoCl}(\text{NH}_3)_5]\text{Cl}_2$
- (4) $[\text{Co}(\text{NH}_3)_6]\text{Cl}_3$

Answer (4)

Sol. The aqueous solution of $[\text{Co}(\text{NH}_3)_6]\text{Cl}_3$ is a type of 1 : 3 type electrolyte as it undergoes dissociation into $[\text{Co}(\text{NH}_3)_6]^{3+}$ and 3Cl^- ions.

67. The standard electrode potential (E°) for the half-cell reaction $\text{Fe}^{3+} + e^- \rightarrow \text{Fe}^{2+}$ at 298 K is

(Given : $E^\circ(\text{Fe}^{3+}/\text{Fe}) = -0.04 \text{ V}$ and $E^\circ(\text{Fe}^{2+}/\text{Fe}) = -0.44 \text{ V}$ at 298 K)

- (1) +0.92 V
- (2) +0.40 V
- (3) +0.76 V
- (4) -0.48 V

Answer (3)

Sol.

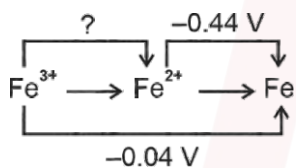

$$\Delta G^\circ_{\text{Fe}^{3+}/\text{Fe}} = \Delta G^\circ_{\text{Fe}^{3+}/\text{Fe}^{2+}} + \Delta G^\circ_{\text{Fe}^{2+}/\text{Fe}}$$

$$-nFE^\circ = -nFE^\circ + -nFE^\circ$$

$$-3F(-0.04) = -1FE^\circ + 2F(0.44)$$

$$3F(0.04) = -FE^\circ + 0.88F$$

$$0.12 = -E^\circ + 0.88$$

$$0.12 - 0.88 = -E^\circ$$

$$-0.76 = -E^\circ$$

$$E^\circ = 0.76 \text{ V}$$

68. In potash alum, the ratio of K^+ and SO_4^{2-} ions is

- (1) 3 : 2
- (2) 1 : 2
- (3) 2 : 1
- (4) 2 : 3

Answer (2)

Sol. Potash alum

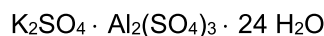

No. of K^+ = 2

No. of SO_4^{2-} = 4

$$\text{Ratio } \frac{K^+}{SO_4^{2-}} = \frac{2}{4} = \frac{1}{2}$$

69. Consider the following statements about the solutions formed by mixing two liquids.

- A. An ideal solution thus formed obeys Raoult's law throughout the composition range.
- B. Mixture of chloroform and acetone shows negative deviation from Raoult's law.
- C. Mixture of aniline and phenol shows positive deviation from Raoult's law

- (1) A and C only
- (2) A and B only
- (3) B and C only
- (4) A only

Answer (2)

Sol. In the case of phenol and aniline solution, the intermolecular hydrogen bonding between phenolic proton and lone pair on nitrogen atom of aniline is stronger than the respective intermolecular hydrogen bonding between similar molecules. Therefore it shows negative deviation.

70. For a salt **XY**, which is a strong electrolyte, the plot of Λ_m versus \sqrt{c} has a slope of $-90.0 \text{ S cm}^2 \text{ mol}^{-3/2}$ $L^{1/2}$ at 298 K. At 0.01 M concentration of **XY**, the value of Λ_m is $145.0 \text{ S cm}^2 \text{ mol}^{-1}$. The limiting molar conductivity of Y^- ion ($\lambda_{Y^-}^0$, in $\text{S cm}^2 \text{ mol}^{-1}$) at 298 K will be

(Given : $\lambda_{X^+}^0 = 74.0 \text{ S cm}^2 \text{ mol}^{-1}$)

- (1) 76.0
- (2) 80.0
- (3) 100.0
- (4) 90.0

Answer (2)

Sol. $y = mx + c$

$$\text{slope} = -90$$

$$\text{According to } \lambda_m = \lambda_m^0 - A\sqrt{c}$$

$$145 = \lambda_m^0 - 90 \times 0.1$$

$$\lambda_m^0 = 154 \text{ S cm}^2 \text{ mol}^{-1}$$

$$\lambda_{m(XY)}^0 = \lambda_{X^+}^0 + \lambda_{Y^-}^0$$

$$154 = 74 + \lambda_{Y^-}^0$$

$$\lambda_{Y^-}^0 = 80 \text{ S cm}^2 \text{ mol}^{-1}$$

71. Arrange the following compounds in the increasing order of polarity

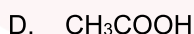
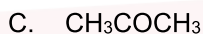
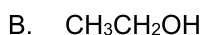
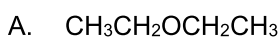

Choose the correct answer from the options given below.

(1) $A < C < B < D$

(2) $A < B < C < D$

(3) $C < A < D < B$

(4) $C < A < B < D$

Answer (1)

Sol. On the basis of polarity the correct order is

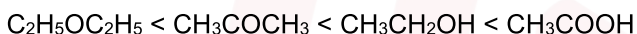

So correct order is

$$A < C < B < D$$

72. According to crystal field theory, the correct order of ligands with respect to their decreasing order of field strength is

(1) $\text{Cl}^- > \text{NH}_3 > \text{H}_2\text{O} > \text{CO}$

(2) $\text{CO} > \text{NH}_3 > \text{H}_2\text{O} > \text{Cl}^-$

(3) $\text{CO} > \text{H}_2\text{O} > \text{NH}_3 > \text{Cl}^-$

(4) $\text{Cl}^- > \text{H}_2\text{O} > \text{NH}_3 > \text{CO}$

Answer (2)

Sol. The correct decreasing order of field strength according to crystal field theory is

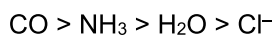

73. The amino acid that gives a red-blood colour on treating its sodium fusion extract with sodium nitroprusside is

- (1) serine
- (2) leucine
- (3) threonine
- (4) methionine

Answer (4)

Sol. In case both nitrogen and sulphur are present in an organic compound, it gives blood red colour with sodium nitroprusside.

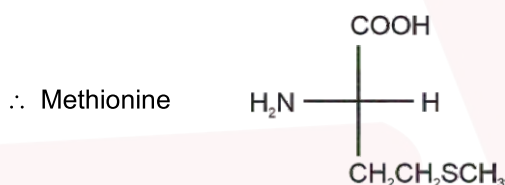

74. In an acidic medium, 10 mL of 0.25 M oxalic acid is titrated with KMnO_4 solution. If the volume of KMnO_4 solution required to reach end point is 10 mL, the strength of the KMnO_4 solution is

- (1) 0.15 M
- (2) 0.10 M
- (3) 0.20 M
- (4) 0.25 M

Answer (2)

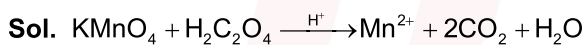

No. of equivalent of KMnO_4 = No. of equivalent of $\text{H}_2\text{C}_2\text{O}_4$

$$10 \times 5 \times M = 10 \times 0.25 \times 2$$

$$M = \frac{5}{50}$$

$$M = \frac{1}{10} = 0.10 \text{ M}$$

75. The correct statement is
- (1) Aluminium has five valence orbitals.
 - (2) Boron has a maximum covalency of four.
 - (3) Beryllium has three valence orbitals.
 - (4) Magnesium has a maximum covalency of four.

Answer (2)

- Sol.**
- Aluminium has nine valence orbitals
 - Beryllium has four valence orbitals
 - Magnesium has a maximum covalency of six.
 - Boron has maximum covalency of four

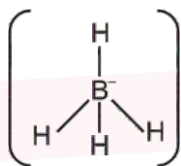

76. Among the following, the compound having conjugated double bonds is
- (1) hepta-1,6-diene
 - (2) hepta-1,3-diene
 - (3) hepta-1,4-diene
 - (4) hepta-1,5-diene

Answer (2)

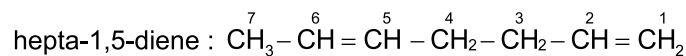
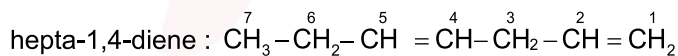
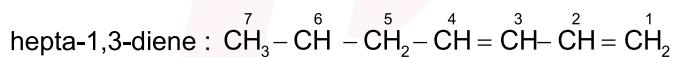
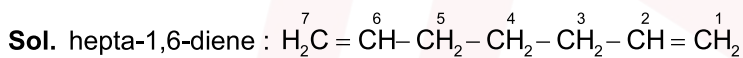

An organic compound (diene) with two double bonds separated by one single bond is termed as conjugated diene.

77. $2A \xrightarrow{k} B$ is a zero-order reaction, where $k = 1.0 \text{ mol L}^{-1} \text{ min}^{-1}$. If the initial concentration of A is 2 M, then the time taken to complete 75% of the reaction will be

- (1) 2.0 min
- (2) 1.5 min
- (3) 0.75 min
- (4) 1.0 min

Answer (3)

Sol. For zero order reaction

$$-\frac{1}{2} \frac{dA}{dt} = k$$

$$t = \frac{A_0 - A_t}{2k}$$

$$t = \frac{2 - 0.5}{2} = 0.75 \text{ min}$$

78. The correct order of solubility of the given salts in water at 298 K is

Salt	K_{sp} at 298 K
AgBr	5.0×10^{-13}
Zn(OH) ₂	1.0×10^{-15}
Hg ₂ Cl ₂	1.3×10^{-18}

- (1) Zn(OH)₂ > AgBr > Hg₂Cl₂
- (2) Hg₂Cl₂ > Zn(OH)₂ > AgBr
- (3) AgBr > Zn(OH)₂ > Hg₂Cl₂
- (4) Hg₂Cl₂ > AgBr > Zn(OH)₂

Answer (1)

Sol. $\text{AgBr}(s) \rightleftharpoons \text{Ag}^+(aq.) + \text{Br}^-(aq.)$

$$K_{sp} = 5 \times 10^{-13} = S^2$$

$$S = \sqrt{5 \times 10^{-13}}, S = 7.07 \times 10^{-7} \text{ mol/L}$$

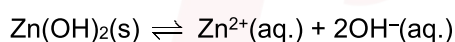

$$K_{sp} = 10^{-15} = (S)(2S)^2$$

$$4S^3 = 10^{-15}, S = 0.63 \times 10^{-5} = 6.3 \times 10^{-6} \text{ mol/L}$$

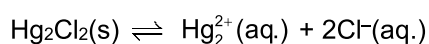

$$K_{sp} = 1.3 \times 10^{-18} = 4S^3, S = 0.69 \times 10^{-6} = 6.9 \times 10^{-7} \text{ mol/L}$$

The correct order of solubility is:



79. The correct decreasing order of oxidation state of the underlined atom in each molecule is

- (1) $\underline{P}_4O_6 > \underline{Cl}_2O_7 > \underline{Al}H_3$
- (2) $\underline{P}_4O_{10} > \underline{S}O_3 > \underline{H}_2O$
- (3) $\underline{N}_2O_5 > \underline{Al}_2O_3 > \underline{H}_2S$
- (4) $\underline{Pb}O_2 > \underline{N}_2O_3 > \underline{S}O_3$

Answer (3)

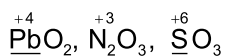
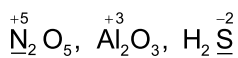
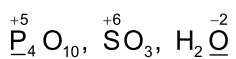
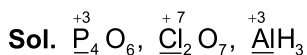

80. Consider the reversible processes for 1.0 mol of an ideal gas as shown in the figure.

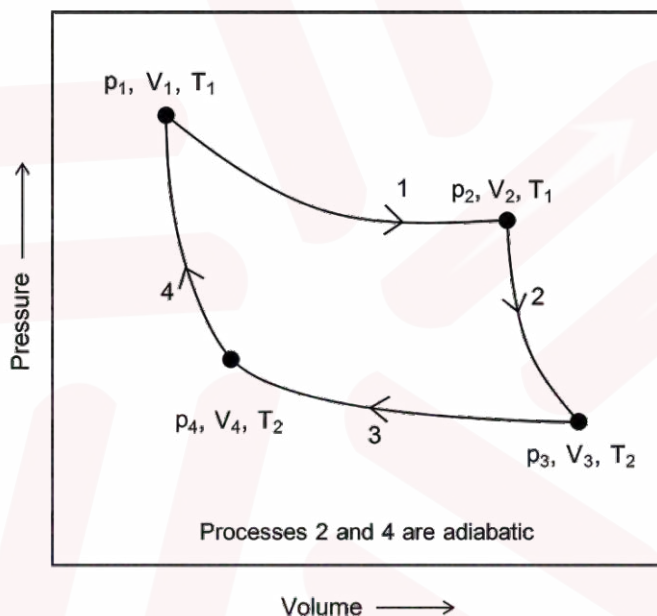

w_1, w_2, w_3 and w_4 represent work done (in calories) in the processes 1, 2, 3 and 4, respectively; ΔU_2 and ΔU_4 are changes in the internal energy for the processes 2 and 4, respectively.

[use $R = 2 \text{ cal K}^{-1} \text{ mol}^{-1}$]

The correct option is

- (1) $w_1 + w_2 + w_3 + w_4 = 0$
- (2) $w_1 + w_3 = -2T_1 \ln \frac{V_2}{V_1} - 2T_2 \ln \frac{V_4}{V_3}$
- (3) $w_2 + w_4 = \Delta U_2 - \Delta U_4$
- (4) $w_1 + w_2 = 2T_1 \ln \frac{V_2}{V_1}$

Answer (2)

Sol. $w_1 \rightarrow$ isothermal reversible process

$$w_1 = -nRT_1 \ln \frac{V_2}{V_1}$$

$$w_1 = -1 \times R \times T_1 \ln \frac{V_2}{V_1}$$

$$w_3 = -n \times R \times T_2 \ln \frac{V_4}{V_3}$$

$$w_3 = -1 \times R \times T_2 \ln \frac{V_4}{V_3}$$

$$w_1 + w_3 = -nRT_1 \ln \left(\frac{V_2}{V_1} \right) - nRT_2 \ln \left(\frac{V_4}{V_3} \right)$$

$$w_1 + w_3 = -2T_1 \ln \left(\frac{V_2}{V_1} \right) - 2T_2 \ln \left(\frac{V_4}{V_3} \right)$$

81. **Assertion A:** For an ideal solution formed by mixing liquids **P** and **Q**, $\Delta_{\text{mix}} H = 0$ and $\Delta_{\text{mix}} V = 0$

Reason R: No interactions occur between **P** and **Q**

In the light of the above statements, choose the **most appropriate** answer from the options given below.

- (1) **A** is not correct but **R** is correct
- (2) Both **A** and **R** are correct and **R** is the correct explanation of **A**
- (3) Both **A** and **R** are correct but **R** is **NOT** the correct explanation of **A**
- (4) **A** is correct but **R** is not correct

Answer (4)

Sol. For ideal solution, $\Delta_{\text{mix}} H = 0$ and $\Delta_{\text{mix}} V = 0$

In Ideal solution energy required to break interaction between P-P and Q-Q will be same as the energy released on the interaction of P-Q.

82. Among the species given below, the spin-only magnetic moment is highest for (Given: Atomic number of Ti = 22, Mn = 25, Fe = 26 and Co = 27)

- (1) $[\text{Ti}(\text{H}_2\text{O})_6]^{3+}$
- (2) $[\text{Mn}(\text{CN})_6]^{3-}$
- (3) $[\text{Fe}(\text{CN})_6]^{3-}$
- (4) $[\text{Co}(\text{NH}_3)_6]^{3+}$

Answer (2)

Sol. In $[\text{Ti}(\text{H}_2\text{O})_6]^{3+} \Rightarrow \text{Ti}^{3+} \Rightarrow [\text{Ar}] 4s^0 3d^1$

Number of unpaired electron = 1

In $[\text{Mn}(\text{CN})_6]^{3-} \Rightarrow \text{Mn}^{3+} \Rightarrow [\text{Ar}] 4s^0 3d^4$

Number of unpaired electrons = 2

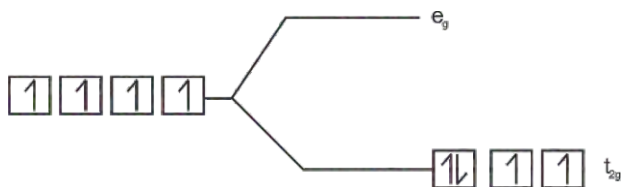

In $[\text{Fe}(\text{CN})_6]^{3-} \Rightarrow \text{Fe}^{3+} \Rightarrow [\text{Ar}] 4s^0 3d^5$

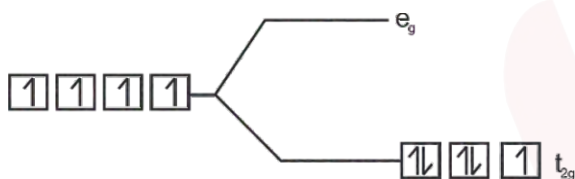

Number of unpaired electron = 1

83. A protein undergoes reversible thermal denaturation from its initial state **N** to denatured state **D** according to $\text{N} \rightleftharpoons \text{D}$. At 60°C, the concentrations of both **N** and **D** are equal at equilibrium, and the standard enthalpy change of denaturation is 666 kJ mol⁻¹. The standard entropy change ΔS° (in kJ K⁻¹ mol⁻¹) of the protein upon denaturation at 60°C is closest to

- (1) 11.1
- (2) 2.0
- (3) 2000.0
- (4) 333.0

Answer (2)

Sol. $\Delta S = \frac{\Delta H}{T}$

$$= \frac{666}{333}$$

$$= 2 \text{ kJ K}^{-1} \text{ mol}^{-1}$$

84. Given below are two statements: One is labelled as **Assertion A** and the other is labelled as **Reason R**.

Assertion A: Generally, 3d transition metals have high melting points.

Reason R: Involvement of 3d-electrons in addition to 4s-electrons in the interatomic metallic bonding.

In light of the above statements, choose the **most appropriate** answer from the options given below:

- (1) **A** is not correct but **R** is correct
- (2) Both **A** and **R** are correct and **R** is the correct explanation of **A**
- (3) Both **A** and **R** are correct and **R** is **NOT** the correct explanation of **A**
- (4) **A** is correct but **R** is not correct.

Answer (2)

Sol. The melting points of 3d transition metals are generally high. This is attributed to the involvement of greater number of electrons from (n - 1) d in addition to the ns electrons in the interatomic metallic bonding.

85. Given below are two statements: One is labelled as **Assertion A** and the other is labelled as **Reason R**.

Assertion A: The first ionization enthalpy of O is lower than that of N and F.

Reason R: The loss of an electron from O leads to stable half-filled *p* orbital

In light of the above statements, choose the **most appropriate** answer from the options given below:

- (1) **A** is not correct but **R** is correct
- (2) Both **A** and **R** are correct and **R** is the correct explanation of **A**
- (3) Both **A** and **R** are correct and **R** is **NOT** the correct explanation of **A**
- (4) **A** is correct but **R** is not correct.

Answer (2)

Sol. N = $1s^2 2s^2 2p^3$

F : $1s^2 2s^2 2p^5$

First ionization enthalpy ($\Delta_i H$)

($\Delta_i H$) for N = 1402 kJ mol⁻¹

$\Delta_i H$ for O = 1314 kJ mol⁻¹

$\Delta_i H$ for F = 1681 kJ/mol

Due to half filled stable electronic configuration of nitrogen, It's first ionization enthalpy is higher than that of oxygen

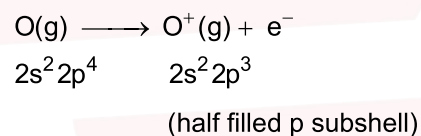

86. Consider the following reaction sequences and choose the correct option.

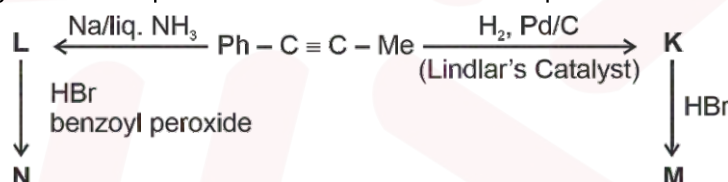

- (1) **M** and **N** are stereoisomers
- (2) **K** and **L** are geometrical isomers
- (3) **K** and **L** are enantiomers
- (4) **M** and **N** are geometrical isomers

Answer (2)

Sol.

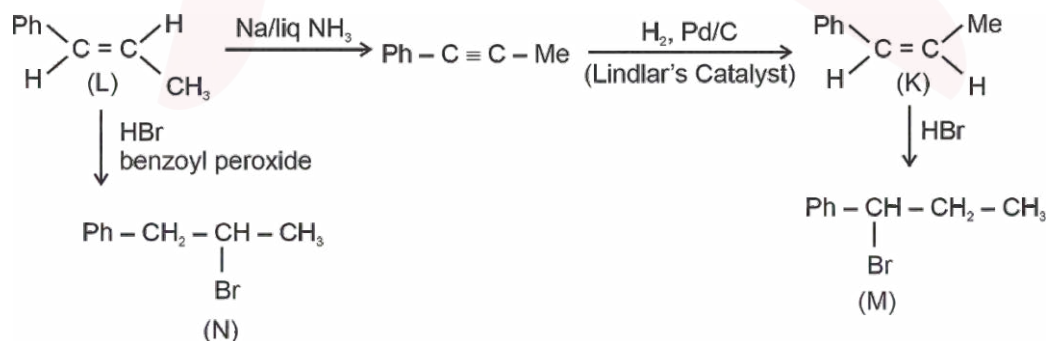

87. The highest occupied molecular orbital for Ne_2 is

- (1) σ_{2p}^*
- (2) π_{2p}
- (3) σ_{2p}
- (4) π_{2p}^*

Answer (1)

Sol. $\text{Ne}_2 : \sigma 1s^2 < \sigma^* 1s^2 < \sigma 2s^2 < \sigma^* 2s^2 < \sigma 2p_z^2 < (\pi 2p_x^2 = \pi 2p_y^2) < \pi^* 2p_x^2 = \pi^* 2p_y^2 < \sigma^* 2p_z^2$

$\sigma^* 2p_z$ i.e. $\sigma^* 2p$ is highest occupied orbital.

88. Match the species in **List-I** with their geometry in **List-II**.

	List-I		List-II
A.	PCl_5	I.	Tetrahedral
B.	BrF_5	II.	Square Planar
C.	BF_4^-	III.	Trigonal bipyramidal
D.	$[\text{Ni}(\text{CN})_4]^{2-}$	IV.	Square pyramidal

Choose the **correct** answer from the options given below:

- (1) A-III, B-II, C-I, D-IV
- (2) A-IV, B-III, C-I, D-II
- (3) A-III, B-IV, C-I, D-II
- (4) A-III, B-I, C-II, D-IV

Answer (3)

Sol.

	Compound	Hybridization of central atom/ion	Geometry
A.	PCl_5	sp^3d	Trigonal bipyramidal
B.	BrF_5	sp^3d^2	Square pyramidal
C.	BF_4^-	sp^3	Tetrahedral
D.	$[\text{Ni}(\text{CN})_4]^{2-}$	dsp^2	Square planar

89. Match the vitamins in **List I** with their sources in **List II**

	List I		List II
A.	vitamin A	I.	meat
B.	vitamin B ₁₂	II.	sunflower oil
C.	vitamin E	III.	green leafy vegetables
D.	vitamin K	IV.	carrots

Choose the correct answer from the options given below.

- (1) A-III, B-I, C-IV, D-II
- (2) A-II, B-III, C-IV, D-I
- (3) A-IV, B-I, C-II, D-III
- (4) A-IV, B-II, C-I, D-III

Answer (3)

Sol.

	Vitamin	Sources
A.	Vitamin A	Carrot
B.	Vitamin B ₁₂	Meat
C.	Vitamin E	Sunflower oil
D.	Vitamin K	Green leafy vegetables

90. For the following reaction sequence, choose the correct option

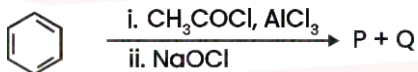

- (1) Both **P** and **Q** are carbonyl compounds
- (2) If **P** is the sodium salt of a carboxylic acid, **Q** is a primary alcohol
- (3) **P** and **Q** are aromatic compounds
- (4) If **P** gives a carboxylic acid on acidification, **Q** gives a poisonous gas on exposure to air and light

Answer (4)

Sol.

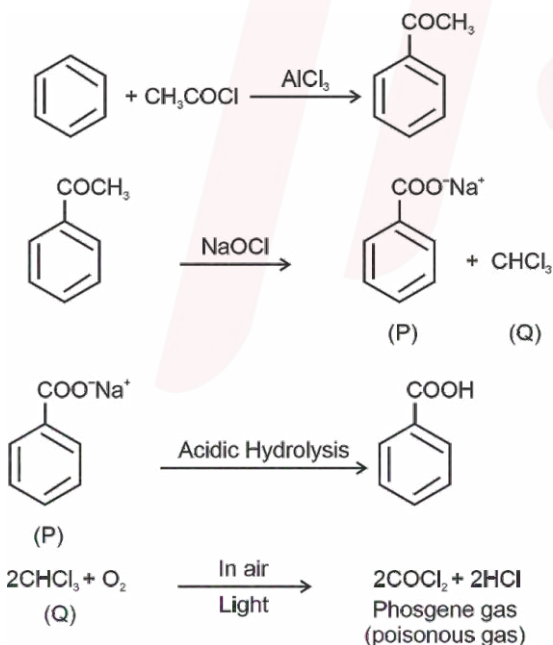

BIOLOGY

91. Given below are two statements:

Statement I : The class name Reptilia refers to creeping or crawling mode of locomotion.

Statement II : All organisms belonging to Reptilia have three chambered heart.

In the light of the above statements, choose the **most appropriate** answer from the options given below:

- (1) **Statement I** is incorrect but **Statement II** is correct
- (2) Both **Statement I** and **Statement II** are correct
- (3) Both **Statement I** and **Statement II** are incorrect
- (4) **Statement I** is correct but **Statement II** is incorrect

Answer (4)

Sol. The class Reptilia refers to their creeping or crawling mode of locomotion. Heart is usually three-chambered, but four-chambered in crocodiles.

So, All organisms belonging to class Reptilia does not possess three chambered heart.

92. How many turns of Calvin cycle are required for the formation of three molecules of glucose?

- (1) 18
- (2) 6
- (3) 3
- (4) 1

Answer (1)

Sol. To make one molecule of glucose 6 turns of the cycle are required.

Therefore, for the formation of three molecules of glucose, $6 \times 3 = 18$, turns of Calvin cycle are required.

93. Photorespiration reaction catalyzed by RuBisCo is shown below:

$\text{RuBP} + \text{O}_2 \rightarrow 3\text{-Phosphoglycerate} + \text{X}$. Identify "X" from the given options:

- (1) Malate
- (2) Phosphoenolpyruvate
- (3) 2-Phosphoglycolate
- (4) Oxaloacetate

Answer (3)

Sol. During the process of photorespiration, RuBP binds with O_2 and RuBP instead of being converted to 2 molecules of PGA, forms one molecule each of phosphoglycerate and phosphoglycolate.

Hence, in the given reaction, the "X" is 2-phosphoglycolate.

94. Given below are two statements:

Statement I: In gymnosperms, the male and female gametophytes remain within the sporangia.

Statement II: In gymnosperms, seeds are not covered.

In the light of the above statements, choose the **most appropriate** answer from the options given below:

- (1) **Statement I** is incorrect but **Statement II** is correct
- (2) Both **Statement I** and **Statement II** are correct
- (3) Both **Statement I** and **Statement II** are incorrect
- (4) **Statement I** is correct but **Statement II** is incorrect

Answer (2)

Sol. In gymnosperm, the male and female gametophytes do not have an independent free-living existence. They remain within sporangia, retained on the sporophyte.

In gymnosperms the ovules are not enclosed by any ovary wall and remain exposed, both before and after fertilisation. The seeds that develop post fertilisation, are not covered, i.e., naked.

95. How many molecules of pyruvic acid are produced at the end of glycolysis from 206 molecules of glucose?

- (1) 412
- (2) 206
- (3) 309
- (4) 103

Answer (1)

Sol. Two molecules of pyruvic acid are formed at the end of glycolysis from one molecule of glucose.

From 206 molecules of glucose, 412 molecules of pyruvic acid are formed.

96. Match **List-I** with **List-II**.

	List-I		List-II
A.	Fusion of protoplasts between gametes	I.	Meiosis
B.	Fusion of two nuclei	II.	Plasmogamy
C.	Generation of haploid spores	III.	Karyogamy

Choose the **correct** answer from the options given below :

- (1) A-I, B-III, C-II
- (2) A-II, B-III, C-I
- (3) A-II, B-I, C-III
- (4) A-III, B-II, C-I

Answer (2)

Sol. Karyogamy involve fusion of two nuclei.

Plasmogamy is fusion of protoplasm.

Meiosis leads to the production of haploid spores.

97. Mitochondrial inner membrane encloses _____ .

- (1) aqueous humor
- (2) matrix
- (3) cytosol
- (4) mucus

Answer (2)

Sol. Mitochondrial inner membrane encloses matrix.

98. Phyllotaxy is the pattern of arrangement of _____ .

- (1) sepals
- (2) leaves
- (3) flowers
- (4) fruits

Answer (2)

Sol. Phyllotaxy is the pattern of arrangement of leaves on the stem.

99. Mad cow disease is caused by _____ .

- (1) *Mycoplasma sp.*
- (2) prions
- (3) viroids
- (4) *Aspergillus sp.*

Answer (2)

Sol. Mad cow disease is caused by prions.

100. Cell theory was formulated by _____ .

- (1) Antonie Von Leeuwenhoek
- (2) Schleiden and Schwann
- (3) Robert Brown
- (4) Singer and Nicolson

Answer (2)

Sol. Cell theory was formulated by Schleiden and Schwann.

101. Which of the following plant growth regulators promotes internode elongation prior to flowering in cabbage?

- (1) Ethephon
- (2) Abscisic acid
- (3) Gibberellin
- (4) Indole butyric acid

Answer (3)

Sol. Gibberellin promotes internode elongation prior to flowering in cabbage.

102. Which pigment has absorption peak at 700 nm in the photosynthetic reaction centre PS I (P700)?
- (1) Carotenoids
 - (2) Chlorophyll b
 - (3) Chlorophyll a
 - (4) Xanthophylls

Answer (3)

Sol. In PSI, the reaction centre chlorophyll a has an absorption peak at 700 nm and hence, is called P₇₀₀.

103. Sphenopsida class belongs to _____.
- (1) pteridophytes
 - (2) bryophytes
 - (3) angiosperms
 - (4) gymnosperms

Answer (1)

Sol. Sphenopsida class belongs to pteridophytes.

104. Which of the following represents the correct sequence of arrangement of bones in the lower limb of humans?
- (1) Femur-tarsal-patella-tibia
 - (2) Femur-tibia-patella-tarsal
 - (3) Patella-femur-tibia-tarsal
 - (4) Femur-patella-tibia-tarsal

Answer (4)

Sol. Each hindlimb consists of 30 bones.

- The bones of the lower limb is femur (thigh bone), A cup shaped bone called patella cover the knee ventrally (knee cap), tibia and fibula, tarsals (ankle bones), metatarsals and phalanges.
- So, the correct sequence of arrangement of bones in the lower limb of humans will be Femur - patella - tibia -tarsal.

105. Which of the following plant growth regulators is used as herbicide?
- (1) Gibberellin
 - (2) 2, 4-D
 - (3) Kinetin
 - (4) Abscisic acid

Answer (2)

Sol. 2, 4-D is an artificial auxin, which is widely used as herbicide.

106. Genus represents _____.
- (1) a group of closely related families
 - (2) an individual plant or animal
 - (3) a population of plants and animals
 - (4) a group of closely related species

Answer (4)

Sol. Genus comprises a group of related species which has more characters in common in comparison to species of other genera.

107. The plastid that stores xanthophyll is known as _____.

- (1) amyloplast
- (2) chloroplast
- (3) chromoplast
- (4) aleuroplast

Answer (3)

Sol. The plastid that stores xanthophyll is known as chromoplast.

108. In water, frogs respire using _____.

- (1) trachea
- (2) skin
- (3) buccal cavity
- (4) lungs

Answer (2)

Sol. Frogs respire on land and in water by different methods. In water, skin acts as aquatic respiratory organ (cutaneous respiration). Dissolved oxygen in the water is exchanged through the skin by diffusion. On land, the buccal cavity, skin and lungs act as the respiratory organs.

109. Which of the following is **not** a characteristic of chordates?

- (1) Presence of post anal part (tail)
- (2) Presence of notochord
- (3) Central nervous system is dorsal
- (4) Absence of gills

Answer (4)

Sol. The members of phylum Chordata shows following features at any stage of life.

- (1) Presence of notochord
- (2) Pharynx perforated by gill slits
- (3) Dorsal, hollow and single central nervous system
- (4) Ventral heart
- (5) A post-anal tail

Gill slits are absent in non-chordates.

110. Smooth endoplasmic reticulum _____ .

- (1) is a site for the synthesis of carbohydrates
- (2) has ribosomes attached to its surface
- (3) is the major site for the synthesis of lipids
- (4) is actively involved in protein synthesis

Answer (3)

Sol. The Smooth Endoplasmic Reticulum (SER) is responsible for synthesis of lipids as well as steroidal hormones. It is not associated with ribosomes and hence appears smooth.

Rough endoplasmic reticulum is actively involved in protein synthesis. Carbohydrate synthesis occurs in chloroplasts.

111. Which of the following are characteristics of prokaryotic cells?

- (a) Ribosomes are made of 50S and 30S subunits
- (b) They can have plasmids
- (c) They contain mesosome
- (d) They have peroxisomes

Choose the **correct** answer from the options given below :

- (1) (a), (b) and (c) only
- (2) (b) and (c) only
- (3) (a) and (c) only
- (4) (a), (c) and (d) only

Answer (1)

Sol. The following are characteristics of prokaryotic cells.

- Ribosomes are made of 50S and 30S subunits (70S Ribosomes)
- They can have plasmids (Extra chromosomal DNA)
- They contain mesosome (Infoldings of plasma membrane)
- They do not possess membrane bound organelles such as peroxisomes.

112. Match **List-I** with **List-II**.

	List-I		List-II
A.	Cristae	I.	Flat membrane sacs in stroma of chloroplast
B.	Cisternae	II.	Infoldings in mitochondria
C.	Thylakoids	III.	Cell membrane
D.	Phospholipid	IV.	Disc shaped sacs in the Golgi apparatus

Choose the **correct** answer from the options given below:

- (1) A-IV, B-III, C-I, D-II
- (2) A-III, B-IV, C-I, D-II
- (3) A-II, B-IV, C-I, D-III
- (4) A-II, B-IV, C-III, D-I

Answer (3)

Sol. Following are the correct matches:

A.	Cristae	II.	Infoldings in mitochondria
B.	Cisternae	IV.	Disc shaped sacs in the Golgi apparatus
C.	Thylakoids	I.	Flat membrane sacs in stroma of chloroplast
D.	Phospholipid	III.	Cell membrane

113. Which of the following statements related to pituitary gland are **correct**?
- It is divided anatomically into adenohypophysis and neurohypophysis
 - It secretes follicle stimulating hormone
 - It secretes melanocyte stimulating hormone
 - It does not secrete prolactin

Choose the **correct** answer from the options given below :

- (b) and (c) only
- (a) and (b) only
- (a), (b) and (c) only
- (c) and (d) only

Answer (3)

Sol. Adenohypophysis of pituitary gland also secretes prolactin.

114. Which of the following statements regarding photorespiration are correct?
- Do not occur in C₃ plants
 - CO₂ is consumed and O₂ is generated
 - Phosphoglycolate is formed
 - No synthesis of ATP and NADPH

Choose the **correct** answer from the options given below:

- (a) and (b) only
- (a) and (d) only
- (c) and (d) only
- (b) and (d) only

Answer (3)

Sol. • Photorespiration can occur in C₃ plants.

- In photorespiration, O₂ is consumed and CO₂ is released.
- Phosphoglycolate is formed as the initial product.
- There is no synthesis of ATP and NADPH in photorespiration.

115. Which of the following statements is **incorrect**?
- Fibrinogen is produced from fibrin
 - Blood coagulates in response to an injury
 - Blood clot consists of fibrins
 - Fibrin is produced from fibrinogen

Answer (1)

Sol. Fibrins are formed by the conversion of inactive fibrinogen in the plasma by the enzyme thrombin.

116. Arrange the following taxonomic categories in ascending order.
- | | |
|-------------|-------------|
| (a) Genus | (b) Class |
| (c) Order | (d) Phylum |
| (e) Family | (f) Kingdom |
| (g) Species | |

Choose the **correct** answer from the options given below :

- | | |
|---------------------------------------|---------------------------------------|
| (1) (f), (c), (b), (g), (d), (e), (a) | (2) (g), (a), (e), (c), (b), (d), (f) |
| (3) (a), (c), (d), (g), (f), (b), (e) | (4) (g), (c), (d), (b), (e), (a), (f) |

Answer (2)

Sol. The following is the arrangement of taxonomic categories in ascending order.

Species (g), Genus (a), Family (e), Order (c), Class (b), Phylum (d), Kingdom (f).

117. Select the correct sequence of experiments that led to a gradual understanding of photosynthesis in green plants.
- (1) Production of glucose → role of air → release of oxygen → absorption spectra of chlorophyll a and b
 - (2) Absorption spectra of chlorophyll a and b → production of glucose → release of oxygen → role of air
 - (3) Role of air → release of oxygen → production of glucose → absorption spectra of chlorophyll a and b
 - (4) Release of oxygen → production of glucose → absorption spectra of chlorophyll a and b → role of air

Answer (3)

Sol. Following is the appropriate sequence of experiments that led to a gradual understanding of photosynthesis in green plants.

Role of air in Glucose (Joseph Priestley's bell jar experiment) 1770



Release of oxygen (Jan Ingenhousz's experiment using aquatic plant)



Production of Glucose (Julius Von Sach's experiment) 1854



Absorption spectra of chlorophyll a and b (T.W. Engelmann's experiment)

118. Match **List-I** with **List-II**.

	List-I		List-II
A.	Starch	I.	Fights infection
B.	Antibody	II.	Energy storage
C.	Concanavalin A	III.	Glucose transport
D.	Glut-4	IV.	Lectin

Choose the **correct** answer from the options given below :

- | | |
|----------------------------|----------------------------|
| (1) A-I, B-II, C-III, D-IV | (2) A-I, B-II, C-IV, D-III |
| (3) A-II, B-I, C-IV, D-III | (4) A-II, B-I, C-III, D-IV |

Answer (3)

- Sol.** Starch → Energy storage
 Antibody → Fight infection
 Concanavalin A → Lectin
 Glut-4 → Glucose transport

119. The number of vertebrae in a human is _____.

- (1) 206
- (2) 7
- (3) 12
- (4) 26

Answer (4)

Sol. The number of vertebrae in adult human is 26.

120. Endomembrane system includes _____.

- (1) Golgi complex, chloroplast, peroxisomes and vacuole
- (2) endoplasmic reticulum, Golgi complex, lysosomes and vacuole
- (3) endoplasmic reticulum, chloroplast, peroxisomes and vacuole
- (4) mitochondria, chloroplast, peroxisomes and vacuole

Answer (2)

Sol. Endomembrane system includes organelles whose functions are coordinated. It includes total four organelles, namely Endoplasmic reticulum, Golgi body, vacuole and lysosomes.

121. Length of the stem at time 0 is 20 cm. The arithmetic growth rate is 30 cm per day. What is the length of the stem at the end of the 7th day?

- (1) 460 cm
- (2) 50 cm
- (3) 170 cm
- (4) 230 cm

Answer (4)

Sol. Arithmetic growth can be expressed as :

$$L_t = L_0 + rt \quad [\text{where, } L_t = \text{length at time 't', } L_0 = \text{Length at time 'zero', } r = \text{growth rate}]$$

$$L_{7^{\text{th day}}} \Rightarrow 20 + 30 \times 7$$

$$\Rightarrow 20 + 210$$

$$\Rightarrow 230 \text{ cm}$$

The length of the stem at the end of 7th day is 230 cm.

122. Match **List-I** with **List-II**.

	List-I		List-II
A.	Spherical	I.	Vibrio
B.	Rod	II.	Cocci
C.	Comma	III.	Spirilla
D.	Spirillum	IV.	Bacilli

Choose the **correct** answer from the options given below :

- (1) A-II, B-IV, C-I, D-III
- (2) A-I, B-III, C-II, D-IV
- (3) A-III, B-II, C-I, D-IV
- (4) A-II, B-I, C-IV, D-III

Answer (1)

Sol. Bacteria are grouped under four categories based on their shape :

Spherical → Coccus

Rod-shaped → Bacillus

Comma-shaped → Vibrium

Spiral → Spirillum

123. The number of action potentials generated by sino-atrial node (SAN) in a healthy human is _____ per minute.

- (1) 120 - 140
- (2) 28 - 30
- (3) 70 – 75
- (4) 100 - 110

Answer (3)

Sol. The number of action potentials generated by sino-atrial node (SAN) in a healthy human is 70 – 75 per minute.

124. Match **List-I** with **List-II**.

	List-I		List-II
A.	Family	I.	Sapindales
B.	Genus	II.	Dicotyledonae
C.	Class	III.	Anacardiaceae
D.	Phylum	IV.	Angiospermae
E.	Order	V.	<i>Mangifera</i>

Choose the **correct** answer from the options given below :

- (1) A-III, B-V, C-II, D-IV, E-I
- (2) A-I, B-V, C-II, D-IV, E-III
- (3) A-II, B-I, C-III, D-IV, E-V
- (4) A-II, B-III, C-V, D-I, E-IV

Answer (1*) (Conceptual errata)

Sol. *Mangifera* represents Genus, Anacardiaceae represents family, Sapindales represents order, Dicotyledonae represents class, Phylum Angiospermae [correct should be division]

125. Which of the following is **not** a part of human central neural system?

- (1) Pericardium
- (2) Arachnoid
- (3) Dura mater
- (4) Pia mater

Answer (1)

Sol. Pericardium is a double walled membranous bag that protects the heart.

Arachnoid, dura mater and pia mater are meninges, which cover the brain inside the skull.

126. Given below are two statements :

Statement I : Chromosomes are fully condensed at the end of prophase I.

Statement II : Meiosis I resembles mitosis.

In the light of the above statements, choose the **most appropriate** answer from the options given below :

- (1) **Statement I** is incorrect, but **Statement II** is true
- (2) Both **Statement I** and **Statement II** are true
- (3) Both **Statement I** and **Statement II** are false
- (4) **Statement I** is correct, but **Statement II** is false

Answer (4)

Sol. The final stage of meiotic prophase-I is diakinesis. So, at the end of prophase-I the chromosomes are fully condensed and the meiotic spindle is assembled to prepare the homologous chromosomes for separation. So, Statement I is correct.

Meiosis II resembles mitosis as it is an equational division.

127. Match **List-I** with **List-II**.

	List-I		List-II
A.	Marginal placentation	I.	<i>Argemone</i>
B.	Axile placentation	II.	Tomato
C.	Parietal placentation	III.	<i>Primrose</i>
D.	Free central placentation	IV.	Pea

Choose the **correct** answer from the options given below :

- (1) A-IV, B-II, C-I, D-III
- (2) A-II, B-IV, C-I, D-III
- (3) A-IV, B-II, C-III, D-I
- (4) A-IV, B-III, C-I, D-II

Answer (1)

- Sol.** Marginal placentation – Pea
Axile placentation – Tomato
Parietal placentation – *Argemone*
Free central placentation – *Primrose*

128. Symbiotic association between fungi and algae are called _____.

- (1) chrysophytes
- (2) lichens
- (3) sponges
- (4) mycorrhiza

Answer (2)

- Sol.** Lichens are symbiotic associations *i.e.* mutually useful associations, between algae and fungi.
Mycorrhiza are associations between fungi and roots of higher plants.

129. Which of the following is **not** a prokaryote?

- (1) Fungi
- (2) Bacteria
- (3) Blue green algae
- (4) Mycoplasma

Answer (1)

- Sol.** The prokaryotic cells are represented by bacteria, blue-green algae, Mycoplasma and PPLO. Fungi are eukaryotic organisms.

130. Arrange the following elements in descending order of their contribution to percentage weight of the human body.

- (a) Oxygen
- (b) Carbon
- (c) Hydrogen
- (d) Nitrogen

Choose the **correct** answer from the options given below :

- (1) (b), (a), (c), (d)
- (2) (a), (b), (c), (d)
- (3) (c), (a), (b), (d)
- (4) (b), (c), (d), (a)

Answer (2)

Sol. The arrangement of elements in descending order of their contribution to percentage weight of the human body is

Oxygen (65%) → Carbon (18.5%) → Hydrogen (9.5%) → Nitrogen (3.3%)

131. Which one of the following statements is **incorrect**?

- (1) β -cells of pancreas secrete insulin
- (2) α -cells of pancreas secrete glucagon
- (3) α -cells of pancreas secrete insulin
- (4) Glucagon stimulates glycogenolysis

Answer (3)

Sol. The two main types of cells in the Islet of Langerhans are called α -cells and β -cells.

The α -cells secrete a hormone called glucagon, while the β -cells secrete insulin.

Glucagon stimulates glycogenolysis while insulin stimulates glycogenesis.

132. Which of the following are characteristic features of Solanaceae family?

- (a) Flowers are bisexual and actinomorphic
- (b) Calyx have five sepals and are united
- (c) Androecium have five stamens and are epipetalous
- (d) Ovary is inferior

Choose the **correct** answer from the options given below :

- (1) (b), (c) and (d) only
- (2) (a), (b) and (c) only
- (3) (d) only
- (4) (a) and (b) only

Answer (2)

Sol. In Solanaceae family, flowers are bisexual and actinomorphic. Calyx include five sepals that are united.

Androecium include five stamens and it is epipetalous. Ovary is superior.

133. Given below are two statements :

Statement I : When any plane passing through the central axis of the body divides the organism into two identical halves, it is called radial symmetry.

Statement II : In phylum Echinodermata, both adults and larvae are radially symmetrical.

In the light of the above statements, choose the **most appropriate** answer from the options given below :

- (1) **Statement I** is incorrect but **Statement II** is correct
- (2) Both **Statement I** and **Statement II** are correct
- (3) Both **Statement I** and **Statement II** are incorrect
- (4) **Statement I** is correct but **Statement II** is incorrect

Answer (4)

Sol. When any plane passing through the central axis of the body divides the organism into two identical halves, it is called radial symmetry. The members of the phylum Echinodermata exhibits radial or bilateral symmetry depending on the stage.

Adult echinoderms are radially symmetrical while larval echinoderms are bilaterally symmetrical.

134. The correct sequence of adult cell cycle phases is _____.

- (1) S-M-G₂-G₁
- (2) G₁-G₂-S-M
- (3) G₁-M-G₂-S
- (4) G₁-S-G₂-M

Answer (4)

Sol. Gap₁ phase is the first phase of interphase. After Gap₁ phase, synthesis phase starts in which DNA replicates, then Gap₂ phase occur and finally cell cycle ends with M phase (mitosis).

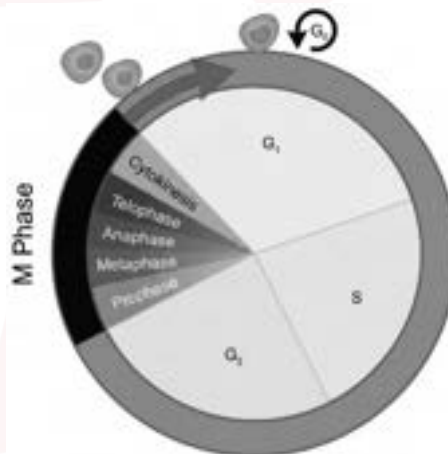

135. In frogs, the number of pairs of cranial nerves arising from the brain are _____.

- (1) 12
- (2) 6
- (3) 9
- (4) 10

Answer (4)

Sol. In frogs, there are ten pairs of cranial nerves arising from the brain.

136. Given below are two statements : one is labelled as **Assertion A** and the other is labelled as **Reason R**.

Assertion A : In recombinant DNA technology, lysozyme is used for disrupting bacterial cells while cellulase is for plant cells.

Reason R : Isolation of genetic material needs disruption of cells.

In the light of the above statements, choose the **most appropriate** answer from the options given below :

- (1) **A** is not correct but **R** is correct
- (2) Both **A** and **R** are correct and **R** is the correct explanation of **A**
- (3) Both **A** and **R** are correct but **R** is not the correct explanation of **A**
- (4) **A** is correct but **R** is not correct

Answer (2)

Sol. Since, the DNA is enclosed within the membranes, we have to break the cell open to release DNA along with other macromolecules such as RNA, proteins, polysaccharides and also lipids. This can be achieved by treating the bacterial cells/plant or animal tissue with enzymes such as lysozyme (bacteria), cellulase (plant cells), chitinase (fungus).

137. The method of directly of injecting a sperm into ovum in assisted reproductive technology is called :

- (1) Embryo transfer (ET)
- (2) Gamete intra fallopian transfer (GIFT)
- (3) Zygote intra fallopian transfer (ZIFT)
- (4) Intra cytoplasmic sperm injection (ICSI)

Answer (4)

Sol. Intra cytoplasmic sperm injection (ICSI) is a procedure to form an embryo in the laboratory in which a sperm is directly injected into the ovum.

ZIFT (Zygote intra fallopian transfer) involves transfer of the zygote or early embryos with upto 8 blastomeres into the fallopian tube.

GIFT (Gamete intra fallopian transfer) involves transfer of an ovum collected from a donor into the fallopian tube of another female who cannot produce one, but can provide suitable environment for fertilisation and further development.

138. Adaptive radiation in placental mammals and Australian Marsupials leading to similarity between distant species is an example of _____.

- (1) genetic drift
- (2) divergent evolution
- (3) convergent evolution
- (4) founder effect

Answer (3)

Sol. When more than one adaptive radiation appeared to have occurred in an isolated geographical area (representing different habitats), one can call this convergent evolution.

Placental mammals in Australia also exhibit adaptive radiation in evolving into varieties of such placental mammals each of which appears to be 'similar' to a corresponding marsupial.

139. Given below are two statements : one is labelled as **Assertion A** and the other is labelled as **Reason R**.
Assertion A : In an experiment, Mendel observed that the F₁ progeny plants are all tall and none are dwarf.
Reason R : Stem height is a contrasting trait, with tall being dominant and dwarf being recessive.

In the light of the above statements, choose the **most appropriate** answer from the options given below :

- (1) **A** is not correct but **R** is correct
- (2) Both **A** and **R** are correct and **R** is the correct explanation of **A**
- (3) Both **A** and **R** are correct but **R** is not the correct explanation of **A**
- (4) **A** is correct but **R** is not correct

Answer (2)

Sol. Mendel crossed tall and dwarf plants and observed that all the F₁ progeny plants are tall.

The trait 'T' or tall is said to be dominant over the other allele 't' or 'dwarf' trait.

It is thus due to this dominance of one trait over the other that all the F₁ are tall.

140. Arrange the following in descending order of number of species in the Amazonian rain forest.
- (a) Plants
 - (b) Birds
 - (c) Fishes
 - (d) Invertebrates
 - (e) Mammals

Choose the **correct** answer from the options given below :

- (1) (b) > (a) > (d) > (c) > (e)
- (2) (c) > (b) > (d) > (e) > (a)
- (3) (d) > (a) > (c) > (b) > (e)
- (4) (e) > (b) > (a) > (c) > (d)

Answer (3)

Sol. The Amazonian rain forest is home to more than 40,000 species of plants, 3,000 of fishes, 1300 of birds, 427 of mammals, 378 of reptiles and of more than 1,25,000 invertebrates.

Hence the correct decreasing order would be

(d) > (a) > (c) > (b) > (e)

141. Sponges exchange O₂ with CO₂ by _____.
- (1) gills
 - (2) simple diffusion over their entire body surfaces
 - (3) moist cuticle
 - (4) tracheal tubes

Answer (2)

Sol. Mechanisms of breathing vary among different groups of animals depending mainly on their habitats and levels of organisation.

Lower invertebrates like sponges, coelenterates, flatworms, *etc.*, exchange O₂ with CO₂ by simple diffusion over their entire body surfaces. Earthworms use their moist cuticle and insects have a network of tubes (tracheal tubes) to transport atmospheric air within the body.

Gills are used by most of the aquatic arthropods and molluscs.

142. For a person with blood group 'O', which of the following is **not** a possible combination of parents' blood group genotypes?
- (1) Father : $I^A I^B$ and Mother : $I^A i$
 - (2) Father : $I^A i$ and Mother : $I^B i$
 - (3) Father : $I^A i$ and Mother : $I^A i$
 - (4) Father : $I^B i$ and Mother : $I^B i$

Answer (1)

Sol. When I^A and I^B are present together they both express their own type of sugars.

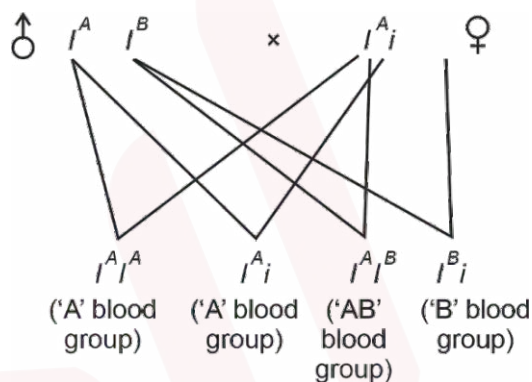

This combination of parent blood group are not possible for a person with blood group 'O'.

For a child to have type 'O' blood, both biological parents must carry the recessive 'O' allele and pass it down.

143. Given below are two statements :

Statement I : Modern *Homo sapiens* arose in Australia and moved across continents.

Statement II : *Homo sapiens* arose around 75000 to 10000 years ago.

In the light of the above statements, choose the **most appropriate** answer from the options given below :

- (1) **Statement I** is incorrect but **Statement II** is correct
- (2) Both **Statement I** and **Statement II** are correct
- (3) Both **Statement I** and **Statement II** are incorrect
- (4) **Statement I** is correct but **Statement II** is incorrect

Answer (1)

Sol. *Homo sapiens* arose in Africa and moved across continents and developed into distinct races.

During ice age, between 75,000 – 10,000 years ago, modern *Homo sapiens* arose.

144. Which of the following is used as an effective sedative and painkiller for treating post-surgery patients?
- (1) Anti-retroviral drugs
 - (2) Interferon
 - (3) Antibiotics
 - (4) Morphine

Answer (4)

Sol. Morphine is a very effective sedative and painkiller and is very useful in patients who have undergone surgery.

Interferon belongs to cytokine barrier of innate immunity.

Antibiotics are used for restricting the growth of bacteria.

145. Which of the following plant produces non-albuminous seeds?

- (1) Pea
- (2) Wheat
- (3) Maize
- (4) Barley

Answer (1)

Sol.

Non-albuminous seeds have no residual endosperm as it is completely consumed during embryo development. E.g. Pea.

Wheat, maize and barley are the examples of albuminous seeds.

146. Given below are two statements : one is labelled as **Assertion A** and the other is labelled as **Reason R**.

Assertion A : Abingdon tortoise in Galapagos islands became extinct within a decade after goats were introduced.

Reason R : Goats were more efficient at browsing than Abingdon tortoise.

In the light of the above statements, choose the **most appropriate** answer from the options given below:

- (1) **A** is not correct but **R** is correct
- (2) Both **A** and **R** are correct and **R** is the correct explanation of **A**
- (3) Both **A** and **R** are correct but **R** is not the correct explanation of **A**
- (4) **A** is correct but **R** is not correct

Answer (2)

Sol. Abingdon tortoise in Galapagos islands became extinct within a decade after goats were introduced on the island, apparently due to the greater browsing efficiency of the goats.

147. The covering of ovum at ovulation is _____.

- (1) chorion
- (2) endometrium
- (3) zona radiata
- (4) zona pellucida

Answer (4)

Sol. The Graafian follicle ruptures to release the secondary oocyte (ovum) from the ovary by the process called ovulation.

The secondary oocyte forms a membrane called zona pellucida surrounding it.

Endometrium is the innermost layer of uterine wall.

Chorion is the outermost extraembryonic membrane that surrounds the embryo.

148. Which of the following is used as a clot buster?

- (1) Statins
- (2) Streptokinase
- (3) Penicillin
- (4) Cyclosporin A

Answer (2)

Sol. Streptokinase produced by the bacterium *Streptococcus* and modified by genetic engineering is used as a 'clot-buster' for removing clots from the blood vessels of patients who have undergone myocardial infarction leading to heart attack.

149. Which of the following structure is **not** a part of the male reproductive system?

- (1) Infundibulum
- (2) Rete testis
- (3) Epididymis
- (4) Vasa efferentia

Answer (1)

Sol. The male sex accessory ducts include rete testis, vasa efferentia, epididymis and vas deferens.

The oviducts, uterus and vagina constitute the female accessory ducts.

Infundibulum is the part of oviduct.

150. Given below are two statements:

Statement I : Ovulation is caused by LH surge leading to rupture of Graafian follicles.

Statement II: Graafian follicle remaining after ovulation transform into corpus luteum and secretes large amount of estrogen.

In the light of the above statements, choose the **most appropriate** answer from the options given below:

- (1) **Statement I** is incorrect but **Statement II** is correct
- (2) Both **Statement I** and **Statement II** are correct
- (3) Both **Statement I** and **Statement II** are incorrect
- (4) **Statement I** is correct but **Statement II** is incorrect

Answer (4)

Sol. Rapid secretion of LH leading to its maximum level during the mid-cycle called LH surge induces rupture of Graafian follicle and thereby the release of ovum (ovulation).

The remaining parts of the Graafian follicle transform as the corpus luteum, which secretes large amounts of progesterone.

151. The opening between the right atrium and the right ventricle is guarded by _____.

- (1) sino-atrial node
- (2) bicuspid valve
- (3) tricuspid valve
- (4) semilunar valve

Answer (3)

Sol. The opening between the right atrium and the right ventricle is guarded by a valve formed of three muscular flaps or cusps, called the tricuspid valve.

A bicuspid/mitral valve guards the opening between the left atrium and the left ventricle.

The openings of the right and the left ventricles into the pulmonary artery and the aorta, respectively, are provided with the semilunar valves.

152. Which of the following is **not** evidence for evolution?

- (1) Divergent evolution of anatomical structures such as forelimbs
- (2) Convergent evolution of traits like wings of birds and butterflies
- (3) Paleontological evidence from fossil records
- (4) Embryological support for evolution as proposed by Ernst Haeckel

Answer (4)

Sol. Haeckel's embryological observations were later considered inaccurate, so this is not accepted as valid evidence in the same way as fossils, homologous organs, or analogous organs.

153. The inactive form of Bt toxin is converted to the active form in the insect gut _____
- (1) by nucleases (2) due to alkaline pH
(3) due to acidic pH (4) by proteases

Answer (2)

Sol. Bt toxin protein exists as inactive protoxins, but once an insect ingests the inactive toxin, it is converted into an active form of toxin due to the alkaline pH of the gut which solubilises the crystals.

154. Colostrum, secreted by mother during initial days of lactation, is abundant in _____.
- (1) IgD (2) IgG
(3) IgM (4) IgA

Answer (4)

Sol. Colostrum, secreted by the mother during the initial days of lactation, is abundant in IgA antibody. IgG antibody passes through the placenta and provides natural passive immunity.

155. Which of the following in female gametophyte of an angiosperm helps in guiding the pollen tube for fertilizing the eggs?
- (1) Polar nucleus (2) Antipodals
(3) Synergids (4) Central cells

Answer (3)

Sol. Synergids guide the entry of pollen tube for fertilizing the eggs, in a typical angiospermic embryo sac.

156. Which of the following disease is **not** sexually transmitted?
- (1) Genital warts
(2) Syphilis
(3) Tuberculosis
(4) Gonorrhoea

Answer (3)

Sol. Genital warts, syphilis and gonorrhoea are sexually transmitted diseases.

Genital warts is caused by Human papilloma virus.

Syphilis is caused by *Treponema pallidum*.

Gonorrhoea is caused by *Neisseria gonorrhoeae*.

Tuberculosis is caused by *Mycobacterium tuberculosis*.

This disease spreads through air.

157. Which of the following statements about lac-operon is **correct**?

- (1) Galactose can act as an inducer of lac operon
- (2) Gene *i* is constitutively expressed
- (3) Lactose activates repressor to bind to the operator
- (4) Genes *i*, *z*, *y* and *a* share single common promoter

Answer (2)

Sol. Galactose cannot act as an inducer of *lac* operon. Gene *i* is constitutively expressed in *lac* operon. Repressor binds to the operator when the lactose is not available. Genes *z*, *y* and *a* are structural genes and have a different promoter than that of the *i* gene.

158. Match **List-I** with **List-II**.

	List-I		List-II
A.	Transformation	I.	Restriction enzyme
B.	Cloning site	II.	Transfer DNA to host bacteria
C.	Selection	III.	Replication
D.	Ori	IV.	Antibiotic

Choose the **correct** answer from the options given below:

- (1) A-IV, B-I, C-III, D-II
- (2) A-II, B-I, C-IV, D-III
- (3) A-I, B-II, C-IV, D-III
- (4) A-III, B-IV, C-II, D-I

Answer (2)

Sol.

- Transformation – Transfer of DNA to the host bacteria
- Cloning site – It is a segment of DNA within a plasmid vector that contains multiple unique recognition sequences for restriction enzymes.
- Selection – Antibiotics help in the selection of recombinants.
- *Ori* – Specific DNA sequence where the host cell's replication machinery begins duplicating the plasmid.

159. A population of diploid organisms is at Hardy-Weinberg equilibrium. If the frequency of allele A is 0.1, the frequency of AA is _____.

- (1) 0.99
- (2) 0.01
- (3) 0.02
- (4) 0.10

Answer (2)

Sol. The frequency of allele A(p) = 0.1

As per the Hardy-Weinberg equilibrium,

Frequency of AA = $p^2 = (0.1)^2 = 0.01$

160. Sperm motility is due to _____.

- (1) muscular movement
- (2) flagellar movement
- (3) ciliary movement
- (4) amoeboid movement

Answer (2)

Sol. Sperm travels across the fallopian tube *via* flagellar movement.

161. Consider a population of 10 million cells. Given the per-capita birth rate of 0.002 (per unit time) and the per-capita death rate of 0.002 (per unit time), the expected number of cells after 10 generations is _____.
- (1) 100 million
 - (2) 1 million
 - (3) 5 million
 - (4) 10 million

Answer (4)

Sol. The per-capita birth rate of bacteria is 0.002.

The per-capita death rate of bacteria is 0.002.

The population dynamic equation is

$$\frac{dN}{dt} = (b - d)N$$

$$\text{Since } r = (b - d) = 0.002 - 0.002 = 0$$

$$\frac{dN}{dt} = 0$$

So, the population remains constant at all times. Thus, even after 10 generations, the expected number of cells will be 10 million.

162. Given below are two statements : one is labelled as **Assertion A** and the other is labelled as **Reason R**.
- Assertion A** : Forelimbs of human and bats are homologous.

Reason R : Forelimbs of humans and bats have similar anatomical structure.

In the light of the above statements, choose the **most appropriate** answer from the options given below.

- (1) **A** is false but **R** is true
- (2) Both **A** and **R** are correct and **R** is the correct explanation of **A**
- (3) Both **A** and **R** are true, but **R** is not the correct explanation of **A**
- (4) **A** is true but **R** is false

Answer (2)

Sol. Forelimbs of bats and humans share similarities in the pattern of bone arrangement.

Though their forelimbs perform different functions, they have similar anatomical structure, as all of them have humerus, radius, ulna, carpals, metacarpals and phalanges in their forelimbs.

Hence, in these animals, the same structure developed along different directions due to adaptation to different needs. This is divergent evolution, and these structures are homologous.

163. Muscle contraction is initiated by a signal sent by the central nervous system by the release of _____ .
- (1) cyclic adenine monophosphate
 - (2) acetyl choline
 - (3) acetyl coenzyme A
 - (4) cyclic guanine monophosphate

Answer (2)

Sol. Muscle contraction is initiated by a signal sent by the central nervous system (CNS) *via* a motor neuron.

The junction between a motor neuron and the sarcolemma of the muscle fibre is called the neuromuscular junction or motor-end plate. A neural signal reaching this junction releases a neurotransmitter (Acetylcholine) which generates an action potential in the sarcolemma.

164. Which of the following hormone is **not** secreted by human placenta?

- (1) LH
- (2) hCG
- (3) Estrogen
- (4) Progesterone

Answer (1)

Sol. The placenta acts as a temporary endocrine gland during pregnancy, secreting several vital hormones essential for fetal development and maintenance of pregnancy.

Several hormones produced by placenta are human chorionic gonadotropin (hCG), human placental lactogen (hPL), estrogen, progestogens, etc.

Luteinizing hormone (LH) is secreted by anterior pituitary.

165. Which of the following statements is **correct** about *Plasmodium*?

- (1) Fertilization takes place in mosquito gut
- (2) Reproduces sexually in liver cells
- (3) Reproduces sexually in RBCs
- (4) Gametocytes develop in mosquito gut

Answer (1)

Sol. *Plasmodium* reproduces asexually in liver cells. *Plasmodium* parasite reproduce asexually in red blood cells, bursting the RBCs and causing cycles of fever and other symptoms. Released parasites infect new red blood cell. Female *anopheles* mosquito takes up gametocytes with blood meal.

Fertilization and development take place in the mosquito's gut.

Sexual stages of *plasmodium* (gametocytes) develop in RBC.

166. Which of the following are primary consumers in a food chain?

- (1) Carnivores
- (2) Parasites
- (3) Predators
- (4) Herbivores

Answer (4)

Sol. Primary consumers in a food chain are the herbivores.

167. Which of the following statements about the reabsorption process in Henle's loop are **correct**?

- (a) The descending limb of Henle's loop is permeable to water but almost impermeable to electrolytes.
- (b) Urine gets concentrated in Henle's loop.
- (c) Reabsorption of Na^+ and water takes place in Henle's loop.
- (d) Active or passive transport of electrolytes occurs in the ascending limb of Henle's loop.

Choose the **correct** answer from the options given below:

- (1) (a), (b) and (d) only
- (2) (a) and (b) only
- (3) (b), (c) and (d) only
- (4) (a), (b) and (c) only

Answer (1)

Sol. Descending limb is permeable to water but almost impermeable to electrolytes. Ascending limb is impermeable to water but allows transport of electrolytes. Hence, urine gets concentrated in Henle's loop.

168. Given below are two statements : one is labelled as **Assertion A** and the other is labelled as **Reason R**.
Assertion A : The logistic growth model of populations is considered more realistic than the exponential growth model.

Reason R : Resources are finite.

In the light of the above statements, choose the **most appropriate** answer from the options given below :

- (1) **A** is not correct but **R** is correct
- (2) Both **A** and **R** are correct and **R** is the correct explanation of **A**
- (3) Both **A** and **R** are correct but **R** is not the correct explanation of **A**
- (4) **A** is correct but **R** is not correct

Answer (2)

Sol. The logistic growth model of populations is considered more realistic than the exponential growth model because resources are limited/finite in nature.

169. Which of the following is the **correct** order of arrangement of vertebrate column from the head to toe?

- (1) Cervical vertebra, thoracic vertebra, lumbar vertebra, sacrum
- (2) Cervical vertebra, thoracic vertebra, sacrum, lumbar vertebra
- (3) Sacrum, lumbar vertebra, thoracic vertebra, cervical vertebra
- (4) Cervical vertebra, lumbar vertebra, thoracic vertebra, sacrum

Answer (1)

Sol. The vertebral column is formed by 26 serially arranged units called vertebrae and is dorsally placed.

The vertebral column is differentiated into cervical (7), thoracic (12), lumbar (5), sacral (1-fused) and coccygeal (1-fused) regions starting from the skull.

So, the correct sequence will be : Cervical, thoracic, lumbar, sacrum and coccyx.

170. Match **List-I** with **List-II**.

	List-I		List-II
A.	Both species are harmed	I.	Predation
B.	One species is harmed and the other is benefited	II.	Mutualism
C.	Both species are benefited	III.	Competition
D.	One is benefited while the other has no effect	IV.	Commensalism

Choose the **correct** answer from the options given below:

- (1) A-III, B-I, C-II, D-IV
- (2) A-III, B-IV, C-II, D-I
- (3) A-I, B-II, C-III, D-IV
- (4) A-II, B-I, C-IV, D-III

Answer (1)

Sol. Both species are harmed in competition.

One species is harmed and the other is benefited in predation.

Both species are benefited in mutualism.

One species is benefited while the other has no effect in commensalism.

171. If the diploid chromosome number of typical angiosperm is 36, what would be the chromosome number in its endosperm?
- (1) 72
 - (2) 18
 - (3) 36
 - (4) 54

Answer (4)

Sol. The endosperm is triploid, if the diploid chromosome number of typical angiosperm is 36

i.e. $2n = 36$ then $n = 18$

$$\begin{aligned} \text{So, } 3n &= n + n + n \\ &= 18 + 18 + 18 \\ &= 54 \end{aligned}$$

172. Which of the following enzymes synthesizes precursor mRNA?
- (1) DNA polymerase
 - (2) RNA polymerase I
 - (3) RNA polymerase II
 - (4) RNA polymerase III

Answer (3)

Sol. The **RNA** polymerase II transcribes precursor of **mRNA**, the heterogeneous nuclear RNA (hnRNA)

173. Given below are two statements :

Statement I : Plasmids are autonomously replicating DNA.

Statement II : Plasmids are extrachromosomal DNA.

In the light of the above statements, choose the **most appropriate** answer from the options given below :

- (1) **Statement I** is incorrect but **Statement II** is correct
- (2) Both **Statement I** and **Statement II** are correct
- (3) Both **Statement I** and **Statement II** are incorrect
- (4) **Statement I** is correct but **Statement II** is incorrect

Answer (2)

Sol. Plasmids are used as cloning vectors in genetic engineering.

- Plasmids are autonomously replicating circular extra chromosomal DNA.
- They have ability to replicate within bacterial cells independent of the control of its chromosomal DNA

174. How many theca are present in each lobe of a typical bilobed angiosperm anther ?
- (1) 12
 - (2) 2
 - (3) 6
 - (4) 8

Answer (2)

Sol. A typical anther is bilobed with each lobe having two theca *i.e.* they are dithecous.

175. Natural selection can lead to _____.
- (a) stabilisation (b) genetic drift
(c) directional change (d) disruption

Choose the **correct** answer from the options given below :

- (1) (a) and (c) only
(2) (a) only
(3) (a), (c) and (d) only
(4) (a), (b), (c) and (d)

Answer (3)

Sol. Natural selection can lead to stabilization, directional change or disruption. Natural selection is a process in which heritable variations enabling better survival enabled to reproduce and leave greater number of progeny. A critical analysis makes us believe that variation due to mutation or recombination during gametogenesis , or due to gene flow or genetic drift results in changed frequency of genes and alleles in future generation.

176. Which of the following statements are **Correct** ?
- (a) Energy flow from producers to consumers is unidirectional
(b) Energy pyramid can never be inverted
(c) Transfer of energy follows the 1% law

Choose the **correct** answer from the options given below :

- (1) (b) and (c) only
(2) (a), (b) and (c)
(3) (a) and (b) only
(4) (a) and (c) only

Answer (3)

Sol. Energy flow is unidirectional. First plants capture solar energy and then, food is transferred from the producers to decomposers.

Pyramid of energy is always upright. It can never be inverted, because when energy flows from a particular trophic level to the next trophic level, some energy is always lost as heat at each step.

The transfer of energy follows 10 per cent law – only 10 per cent of the energy is transferred to each trophic level from the lower trophic level.

177. Match **List-I** with **List-II**.

List-I	List-II
(A) Excess growth hormone	(III) Acromegaly
(B) Luteinizing hormone	(IV) Ovulation
(C) Vasopressin	(I) Reabsorption of water and electrolytes in kidney
(D) Oxytocin	(II) Contraction of uterus during child birth

Choose the **correct** answer from the options given below:

- (1) A-IV, B-III, C-I, D-II (2) A-III, B-IV, C-II, D-I
(3) A-III, B-IV, C-I, D-II (4) A-II, B-IV, C-I, D-III

Answer (3)

Sol. Excess GH causes acromegaly, LH induces ovulation, vasopressin promotes water reabsorption, and oxytocin stimulates uterine contractions.

178. Which of the following are secondary lymphoid organs?

- | | |
|-----------------|-------------|
| (a) Bone marrow | (b) Tonsils |
| (c) Spleen | (d) Thymus |

Choose the correct answer from the options given below:

- | | |
|----------------------|----------------------|
| (1) (a) and (d) only | (2) (a) and (b) only |
| (3) (b) and (c) only | (4) (b) and (d) only |

Answer (3)

Sol. Bone marrow and thymus are primary lymphoid organs while tonsils, spleen are secondary lymphoid organs.

179. During PCR, primers bind to the DNA strands in the _____ step.

- | | |
|---------------|------------------|
| (1) ligation | (2) denaturation |
| (3) extension | (4) annealing |

Answer (4)

Sol. PCR involves three steps, *i.e.* denaturation, annealing and extension.

During PCR, primers bind to the DNA strands in the annealing step.

180. Given below are two statements :

Statement I : Down's syndrome is caused by the absence of one of the X-chromosomes.

Statement II : Turner's syndrome is caused by the presence of an additional copy of the chromosomes.

In the light of the above statements, choose the **correct** answer from the options given below :

- (1) **Statement I** is incorrect but **Statement II** is correct
- (2) Both **Statement I** and **Statement II** are correct
- (3) Both **Statement I** and **Statement II** are incorrect
- (4) **Statement I** is correct but **Statement II** is incorrect

Answer (3)

Sol. The cause of genetic disorder-Down's syndrome is the presence of an additional copy of the chromosome number 21 (Trisomy 21).

The cause of genetic disorder-Turner's syndrome is the absence of one of the X-chromosomes; *i.e.* 45 with X0.





One exam does not define your potential. What you do next does

Didn't get the result you hoped for in NEET?
Your medical dream is still within reach.

Sparkl's **NEET Repeater Program** helps students improve scores through personalized mentoring, targeted practice, and continuous performance tracking—so they can return stronger, smarter, and more confident next year.

Why Repeaters Choose Sparkl



Personalized Learning Journey

Customized study plans tailored to your needs



Expert Faculty & Mentorship

Guidance from experienced NEET educators



Adaptive Learning Technology

Pinpoint weaknesses and improve faster



Tests, Analysis & Feedback

Practice smarter with data-driven insights



Proactive Doubt Support

Get help when you need it



3 D Concept Labs

Teacher-guided visual learning through interactive 3D simulations



Subject-Specific Courses Available

Need help in Physics, Chemistry, or Biology? Individual subject coaching options are also available.



See Your Predicted NEET 2027 Score & AIR Every Step of the Way

Get an estimated NEET 2027 score and AIR from every test attempt.



Flexible Schedules

Monday–Saturday
Between 10 AM – 9 PM



Flexible Learning Formats

Choose the learning style that works best for you:

- 1:1 Personalized Tutoring
- Small Groups (1:4)
- Focused Batches (1:8)

Discover how a personalized strategy can help you achieve your target score.

Book a FREE Demo Session
(Limited slots available for NEET Repeaters.)

Still unsure about taking a drop year?

Talk to a NEET Mentor.

Get a personalized preparation roadmap - FREE.

Call: 8527171054 or

